

570 RIM EXIT DEVICE - REVERSIBLE (NON HANDED) INSTALLATION INSTRUCTIONS

1.) DOOR PREPARATION:

Draw the center line of the device across the door & frame at 40 5/16" (1024) above floor.

- A. If door has preparation for 2 3/4" (70) backset cylindrical lock, mount panic strike using center of 2 1/8" (54) diameter lock hole
- B. If your door has cylindrical lock cut-out for ANSI A115.2 and A115.3 prep doors:

- B1. Extend horizontal and vertical center lines of cut-out shown at right.
- B2. If frame has 5/8" (16) stop, align center lines on template with center lines on door. Drill template holes as described above and follow steps three thru seven.
- B3. If frame has 1/2" (12.7) stop, align center lines on template with center lines on door and spot mounting holes for latch assembly only. Then move template up against stop and spot mounting holes for strike. Drill two mounting holes. Now follow steps three thru six. Note special shim shown at right, which is mounted beneath strike.

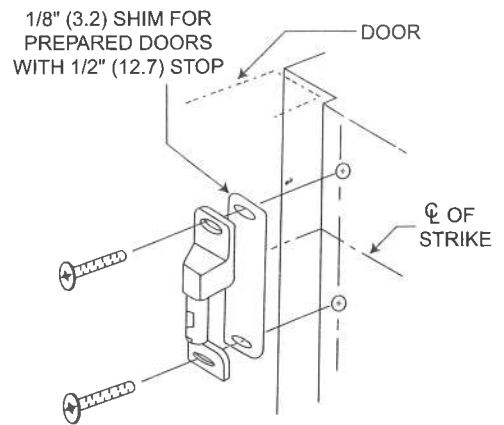
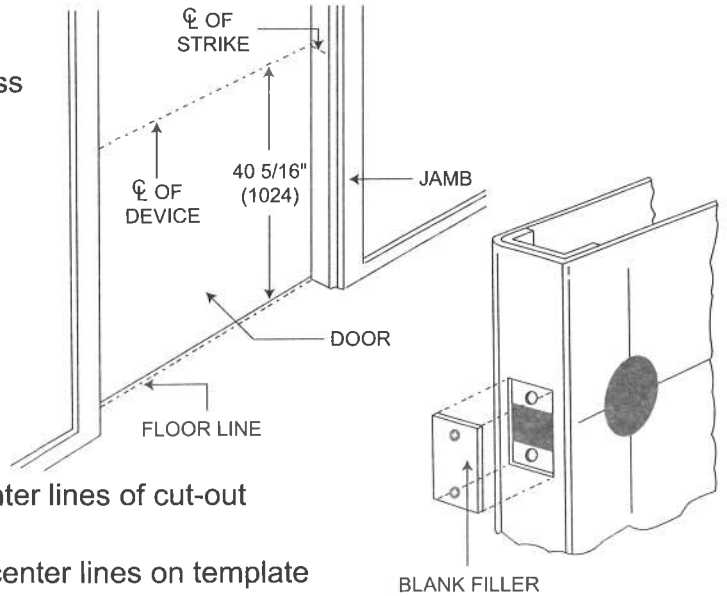

TWIST DRILL SIZES					
Screw Diameter	*Machine Screws	Self Tapping Screws			
		All Door Gauges	24 GA.	20 GA.	18 GA.
#8	#29 (3.5)	1/8" (3.2)	1/8" (3.2)	#30 (3.3)	#29 (3.5)
#12	#16 (4.5)	#19 (4.2)	#19 (4.2)	#18 (4.3)	#16 (4.5)

*Machine screws are intended for use with doors having sufficient metal thickness for proper tapping (reinforced doors) or sex bolts.

SCREW CHART		
Item	Q'ty	Fastener
Front plate assembly and rear bracket	4	#12 x 1 1/4" Lg. pan head tapping screws type "A"
Strike	2	#12 x 1 1/4" Lg. pan head tapping screws type "A"
Edge Filler	4	2 #8-32 x 1/2" machine screw, 2 #8 x 1" pan head tapping screw
Strike Filler	4	2 #12-24 x 1/2" flat hd. machine screw, 2 #12 x 3/4" pan hd. tapping screw

Drill sizes for screws are recommended but various factors, such as type of door and frame construction, thickness and type of metal, etc. can affect the final hole diameter and resulting holding strength of the fastener.

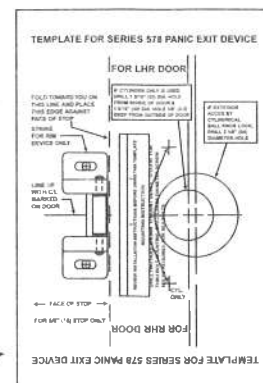
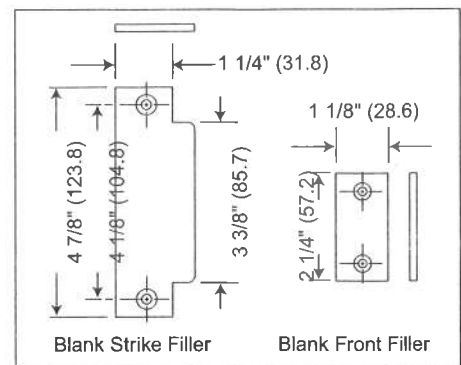

2.) LOCATE AND DRILL TEMPLATE HOLES:

Locate and drill mounting holes for trim, device and strike using furnished template.

Dim inside () are in mm.

3.) TRIM INSTALLATION:

Cut off length of cylinder connecting bar so that 1/2" (12.7) projects beyond inside of door.

**ALWAYS REFER TO TEMPLATE
PACKED WITH TRIM BEFORE
PROCEEDING WITH INSTALLATION**

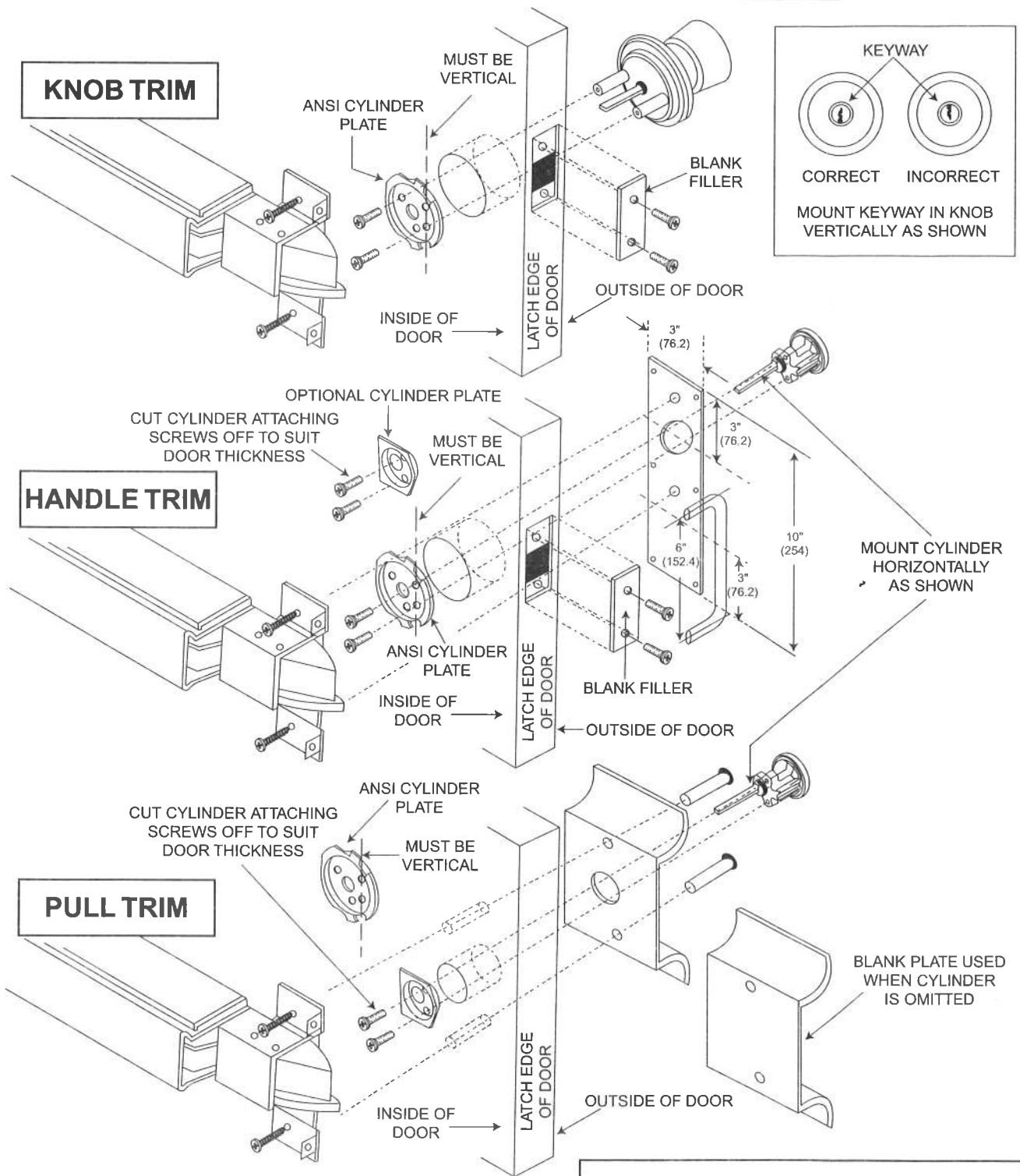

CAUTION:
WHEN USING THE ANSI CYLINDER PLATE BE SURE THE BOSSES ON THE LATCH ASSEMBLY FIT INTO THE CUTOUTS ON THE CYLINDER PLATE SO THAT THE LATCH ASSEMBLY LIES FLAT ON THE DOOR.

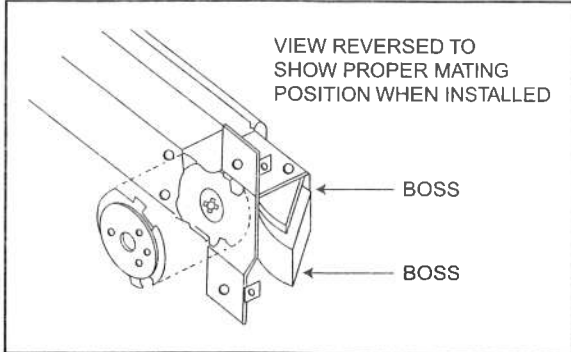

Dim inside () are in mm.

4.) BAR LENGTH ADJUSTMENTS:

- A. Calculate the length to be cut (A).
- B. Remove the rear cover and rear mounting bracket.
- C. Depress push bar and cut off to desired length.
- D. Replace the rear cover and rear mounting bracket.

*RL (Required length) = Door width minus 4" (101.6)

**A = Length of device - Required length (RL)

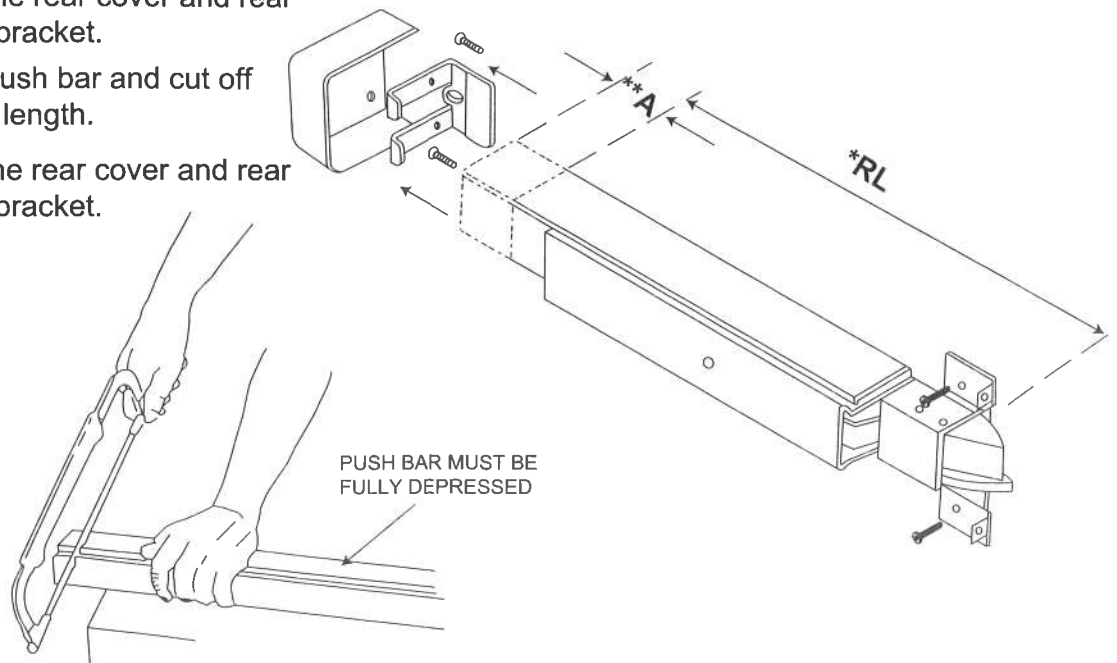

5.) MOUNTING THE DEVICE:

Attach latch to door but do not tighten screws. Assemble rear mounting bracket to push bar (see nesting arrangement in exploded view). Use rear mounting bracket as a template to spot holes for mounting screws. Push bar should be level. Drill screw holes and attach rear mounting bracket and plate to door. Secure latch screws and attach front and rear covers.

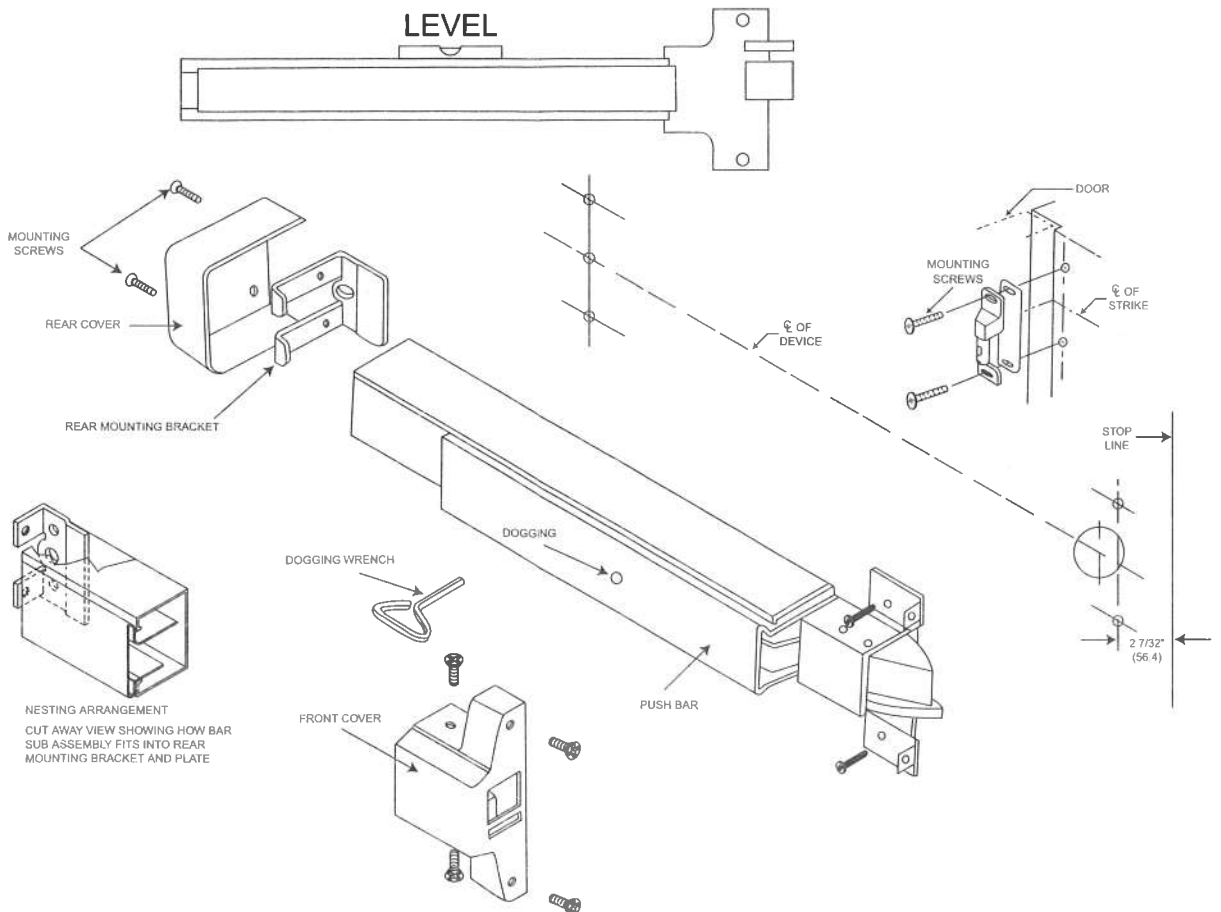

Dim inside () are in mm.

6.) HOW TO TEST PUSH BAR AND DOGGING DEVICE:

- A. Latch bolt is retracted by the push bar inside.
- B. Latch bolt is retracted by the push bar inside and the key outside. Turning the key in either direction will retract the latch. Return key to the horizontal position to remove key and project latch.
- C. Latch bolt is retracted by the push bar inside and the key or knob outside.
To lock knob: Insert key in cylinder and turn counter clockwise as far as key will turn. Then return key to its vertical position and withdraw key.
To unlock knob: Insert key in cylinder and turn clockwise as far as key will turn (the latch will retract during this procedure). Then return key to its vertical position and withdraw key.
- D. **Dogging:** Depress push bar. Insert dogging wrench and turn clockwise 90°. The push bar will remain depressed and the latch will remain retracted.

7.) HOW TO REMOVE & REINSTALL CYLINDER IN LOCK:

A. Removing the knob:

- A1. Insert key in cylinder and turn 90° clockwise.
- A2. Insert knob removing tool into the hole in the knob and depress the knob catch button.
- A3. While knob catch button is depressed pull knob off.

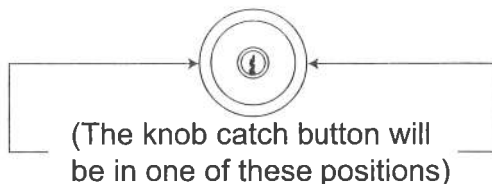
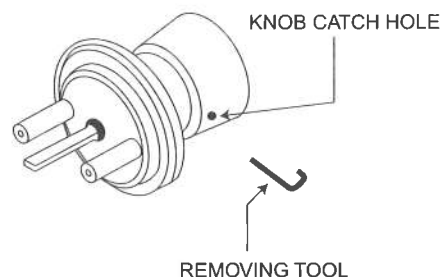

B. Removing cylinder from knob:

- B1. Remove sleeve
- B2. Remove key.
- B3. Slide cylinder out of knob.

C. Reinstalling cylinder in knob:

- C1. Slide cylinder into knob.
- C2. Replace sleeve.

D. Reinstalling the knob:

- D1. With key inserted part way into cylinder slide knob onto knob shank.
- D2. Depress knob catch button and push knob on to the knob shank as far as it will go.
- D3. Insert key completely into the cylinder and turn the key while pushing on the knob until it engages the knob catch button.
- D4. Return key to its vertical position and remove it.
- D5. Pull on the knob to be certain it is properly engaged to the knob catch button.

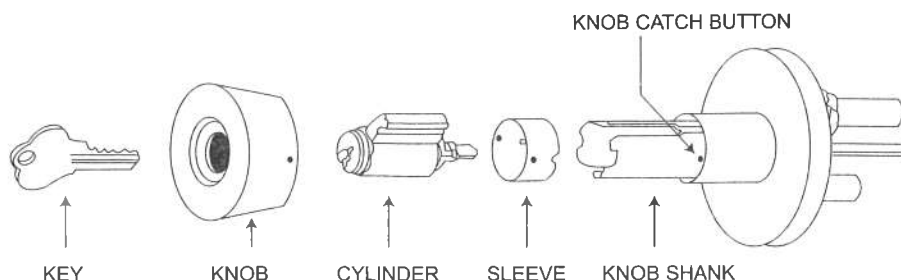

TEMPLATE FOR RIM EXIT DEVICE

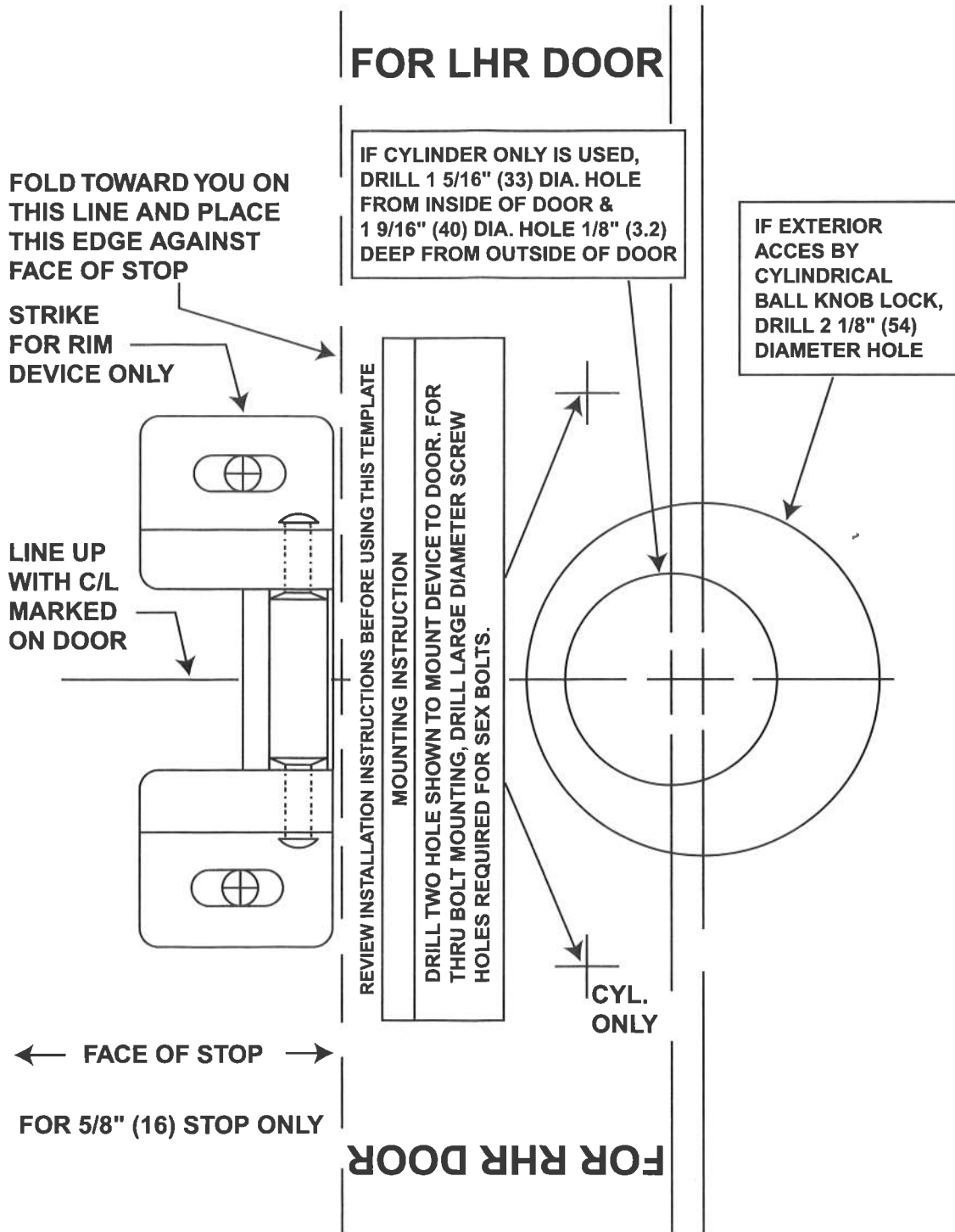

TEMPLATE FOR RIM EXIT DEVICE