

INSTALLATION

ES62/ES62LM/ES62F/ES62FLM

Electric Strikes

Installations of this RIM strike qualify as "Indoor Use Only" when not continuously exposed to an outdoor environment. **Important:** These Electric Strikes are never to be used as a door stop. Please install stops on frame in appropriate locations. Ensure the exit device functions as intended for life safety concerns by verifying electric strike and exit device compatibility. Maximum latch projection is essential to obtain full holding force.

When installed in a fail secure manner, the local Authority Having Jurisdiction shall be consulted with regard to the use of selected panic hardware to ensure emergency exit through secured area.

Catalog Specifications

Mode	Voltage	Current	Duty	Amps	Ohms
Fail Secure	12V	DC	Continuous	0.50	22
Fail Secure	24V	DC	Continuous	0.24	89

Fail Locked = Fail Secure = FSE DC = Direct Current
 Continuous Duty = Energized 1 minute or more

Dimensional Details

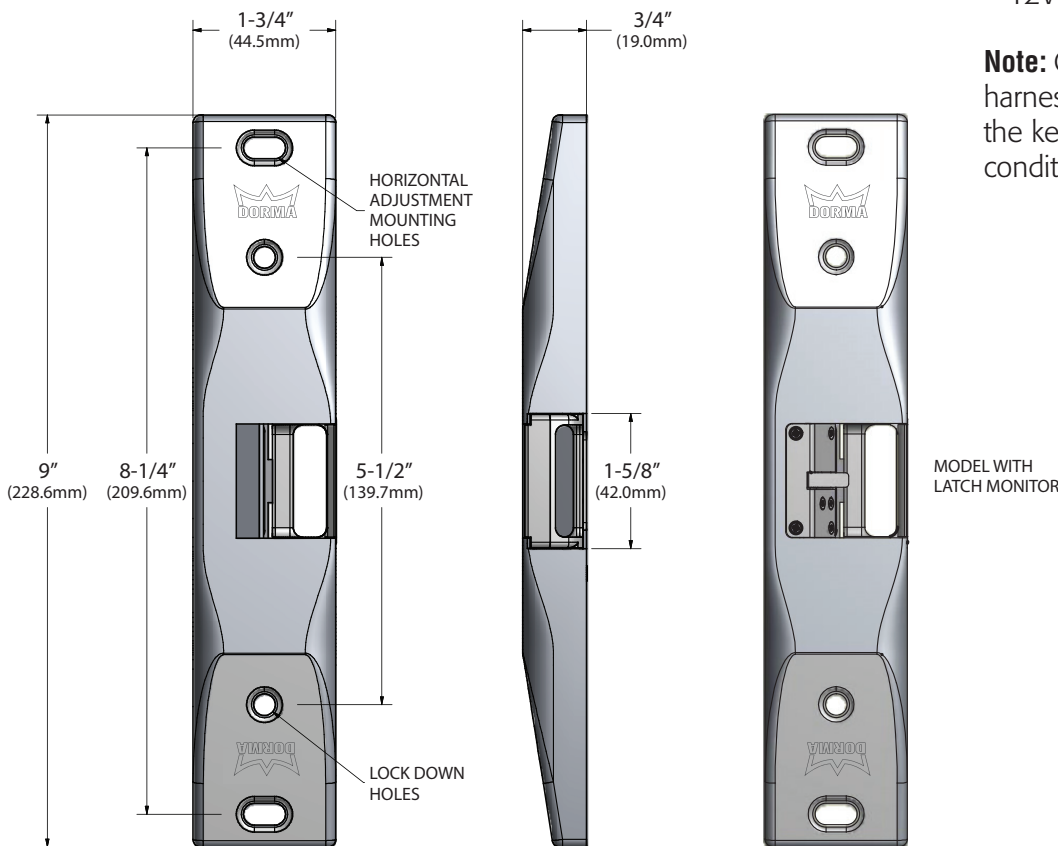

Electrical Latch Monitor Specification:

- 12VDC, 1A, resistive load

Note: Contacts identified on the harness sleeve are indicated with the keeper in a closed and locked condition, with no latch present

Instructions

1. Determine the horizontal centerline of the exit device latch and transfer centerline to the frame stop.
2. Position the template onto the frame aligning with centerline and against the closed door. Center-punch the two mounting holes and the wire access hole(s) as shown.
3. Drill and tap the two mounting holes and drill the wire access hole(s).
4. Test fit electric strike to ensure full latch engagement. Add provided spacer if required.
5. Make wire connections from the power source to the appropriate wire harness supplied. Use the 12V harness for 12VDC. Use the 24V harness only for 24VDC.

NOTE: Overheated or burnt coils caused by incorrect input voltage / wire harness combinations will not be covered under warranty.

6. Connect monitor wires of LM model per harness sleeve.
7. Mount the electric strike with 1/4-20 UNC screws provided in the horizontal mounting holes (the outer slots). Adjust electric strike horizontally until exit device latch fully engages with the door closed (see Fig. 1)

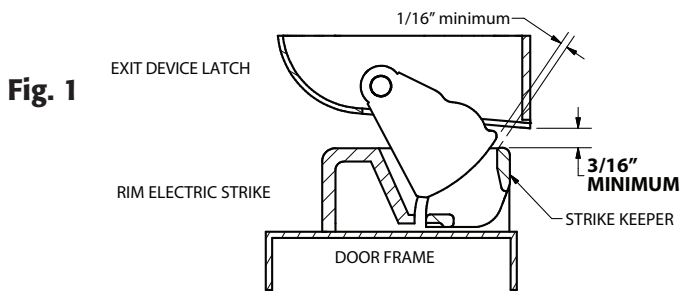

NOTE: Ensure a 1/16" [1.5mm] clearance between exit device latch and the electric strike keeper is maintained. Failing to do so will preload the strike and in turn will not allow the strike to release the door upon energizing.
WARNING: For proper operation, a 3/16" gap (minimum) is required.

8. Tighten the two mounting screws and check operation. Adjust the horizontal position of electric strike as required.
9. Use the electric strike as a template to mark the two locking holes. Remove strike. Drill & tap for 1/4-20 UNC locking screws. Using the 1/4-20 UNC screws provided secure the electric strike through the locking holes (see Fig. 2).

Fig. 2

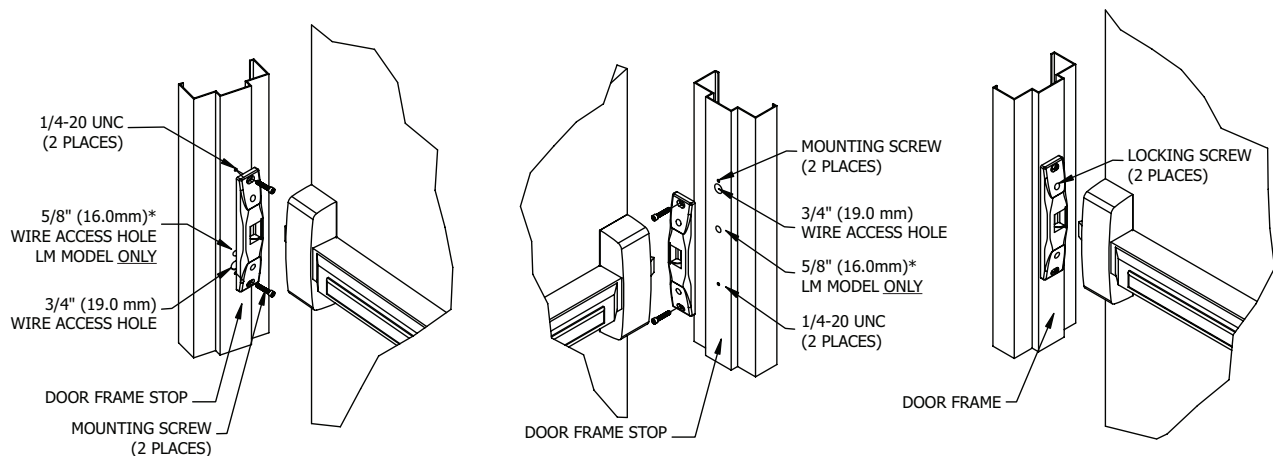

NOTE: Wire access hole locations are relative to the exit device orientation.

NOTE: *Second wire access hole required for ES62(F)LM only

NOTE: Not to scale. Specifications are subject to change without notice.