



# COMFORTDRIVE

---



Original Operating Instruction Manual  
Fully Automatic Operator  
for Movable Walls / Operable Partitions

EG Konformitätserklärung  
EC Declaration of Conformity  
CE Déclaration de conformité



**DORMA Hüppe Raumtrennsysteme GmbH + Co. KG**  
**Industriestraße 5**  
**26655 Westerstede-Ocholt**  
**Germany**

als verantwortlicher Hersteller des / as the responsible manufacturer for the / en tant que fabricant responsable de la

**Vollautomatischen Trennwandsystems**  
**MOVEO Comfortdrive**  
**Variflex Comfortdrive**  
**Varitrans Comfortdrive**  
**HSW Comfortdrive**

erklärt hiermit die Übereinstimmung der, nach oben genannter Bauart gefertigten, Anlagen mit den einschlägigen Bestimmungen folgender Richtlinien des Europäischen Parlaments und des Rates / hereby confirms that products/systems corresponding to the above type of construction comply with all the relevant requirements of the following directives of the European Parliament and of the Council / déclare par la présente la concordance des installations, fabriquées suivant le mode de construction mentionné ci-dessus, avec les dispositions pertinentes de sécurité des Directives du Parlement Européen et du Conseil:

- |                                     |                    |  |
|-------------------------------------|--------------------|--|
| <input checked="" type="checkbox"/> | 2006/95/EG         | Niederspannungsrichtlinie / Low Voltage Directive / Directive basse tension                          |
| <input type="checkbox"/>            | 89/106/EWG/EEC/CEE | Bauprodukte / Building products / Produits de construction   |
| <input checked="" type="checkbox"/> | 2004/108/EG        | Elektromagnetische Verträglichkeit / Electromagnetic compatibility / Compatibilité électromagnétique |
| <input checked="" type="checkbox"/> | 2006/42/EG         | Maschinenrichtlinie / Machinery directive / Directive machine  |

Die technischen Unterlagen sind erhältlich beim Manager Productcompliance unter: / the technical documentation can be obtained from the Manager Product Compliance at / les documents techniques peuvent être obtenus du Manager Product Compliance sous: [product.compliance@dorma.com](mailto:product.compliance@dorma.com)

Es wurden die produktrelevanten Abschnitte der folgenden Normen und Bestimmungen angewandt / In view of the relevant paragraphs for the product, this declaration is based on the following applied standards and rules / En tenant compte des paragraphes relatifs aux produits, cette déclaration est basée sur les suivantes normes et dispositions appliquées:

- |   |  |  |                                  |
|---|--|--|----------------------------------|
| Harmonisierte europäische Norm, nationale Regel /   | <input checked="" type="checkbox"/> EN 13849-1       | <input checked="" type="checkbox"/> EN 61000 - 3 - 2 | <input type="checkbox"/> EN 1154 |
| Harmonized European standards, national rule /      | <input checked="" type="checkbox"/> EN ISO 14121-1   | <input checked="" type="checkbox"/> EN 61000 - 3 - 3 | <input type="checkbox"/> EN 1155 |
| Norme européenne harmonisée, disposition nationale: | <input checked="" type="checkbox"/> EN ISO 12100-1   | <input type="checkbox"/> EN 55014                    | <input type="checkbox"/> EN 1158 |
|   | <input type="checkbox"/> EN ISO 12100-2              | <input type="checkbox"/> EN 55022                    | <input type="checkbox"/> EN 1125 |
|   | <input checked="" type="checkbox"/> ASR A1.7         | <input checked="" type="checkbox"/> EN 60335 - 1     | <input type="checkbox"/> EN 179  |
|   | <input checked="" type="checkbox"/> EN 61000 - 6 - 2 | <input type="checkbox"/> EN 60950 - 1                | <input type="checkbox"/>         |
|   | <input checked="" type="checkbox"/> EN 61000 - 6 - 3 | <input type="checkbox"/>                             | <input type="checkbox"/>         |

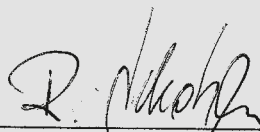
  
Rainer Scholzen

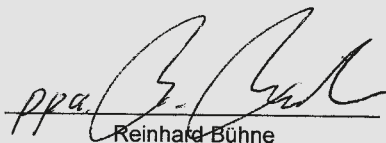
  
Reinhard Bühne



Ocholt, 23.06.2015

Reg.-Nr.: CE\_K\_CD\_20150623

# FULLY AUTOMATIC OPERATOR FOR MOVABLE WALLS/ OPERABLE PARTITIONS



## ABOUT THIS MANUAL

The operation and upkeep of DORMA ComfortDrive systems may only be undertaken by properly instructed personnel capable of implementing the

procedures described herein. The user must check after opening and closing the movable wall/operable partition (hereinafter referred to as

simply “partition”), whether the predetermined end position of the elements has been reached in each case. This instruction manual should

be retained throughout the service life of the DORMA ComfortDrive system. Users are required to comply with the instructions contained herein.

## SAFETY INSTRUCTIONS

- **It is essential that these instructions be followed in order to ensure the safety of personnel. This instruction manual must be kept in a safe place.**
- Before using the ComfortDrive partition system it is essential that the operating manual be read through so as to better ensure safe usage.
- If a defective power supply cable is discovered, the entire power supply unit involved must be replaced with an original spare.
- The power supply system, the elements and the track system must remain unchanged. Unauthorized technical modifications to the system may give rise to damage to property and injury to personnel.
- Unauthorized intervention in system components will result in the warranty becoming null and void.
- When operating the partition, ensure that there are no people or objects within the travel path. **The residual risk of consequential injury cannot be precluded.**
- Keep hands away from all travelling or moving objects.
- The ComfortDrive operating system with its corresponding partition elements must be used exclusively for interior partition purposes.
- **This partition is not intended for use by people (including children) with restricted physical, sensorial or mental capabilities or who lack the experience and/or the knowledge required of a versed user, unless they are supervised by someone responsible for their safety or unless they have received from that person instructions as to how the partition should be used. Children must be supervised at all times in order to ensure that they do not play with this partition.**

## SYMBOLS USED



**Hazard symbol – ensure full compliance with the instructions provided here in order to avoid injury and damage!**



**You need to fully comply with these instructions as otherwise the correct functioning of the partition can no longer be ensured!**

## COMFORTDRIVE FUNCTIONAL PRINCIPLE

The system comprises partition elements which travel under fully automatic control in overhead (ceiling-mounted) tracks. The partition is designed so that the force exerted by the drive motors constantly remains within the non-hazardous range.

The closing forces between the elements are thus non-hazardous to personnel. If partition travel is impeded (by an obstacle or person in the travel path, dirt in the guide track, etc), the hindered partition element stops for

approximately 4 seconds. It then travels 10cm in reverse, and after approx. 5 seconds the element repeats the forward travel attempt. If it is once again impeded within a distance of 50cm over the same section, the partition is brought to a

complete standstill. After the obstruction has been removed, the partition can be restarted in either direction by pressing OPEN or CLOSE.

## OPERATIONAL CONTROL

The partition is operated using the push button panel, at least one EMERGENCY STOP push button and possibly also a key switch. Each partition may have up to two push button panels, 1 to 2 key switches and essentially any number of EMERGENCY STOP push

buttons connected within the network.

**In the case of the push button panel, the commands OPEN, CLOSE and STOP are initiated by pressing the appropriate button as designated. POS1 and POS2 provide you with further partition positioning functions**

**and are programmed in accordance with your requirements. (For further information, please talk to your contact at DORMA Hüppe Raumtrennsysteme GmbH + Co. KG.)**

In the event of a fault occurring in the automatic mode (e.g. a power failure), the partition can be locked, unlocked and moved by hand.

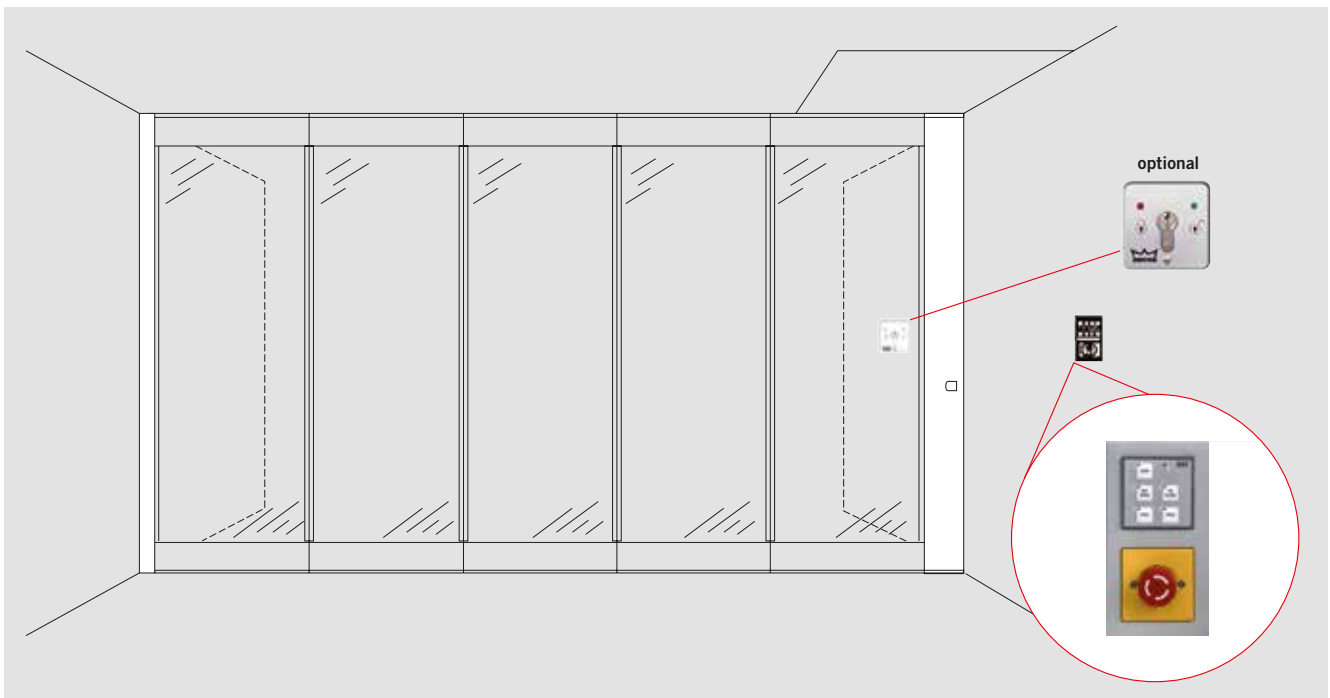

## PUSH BUTTON PANEL

---

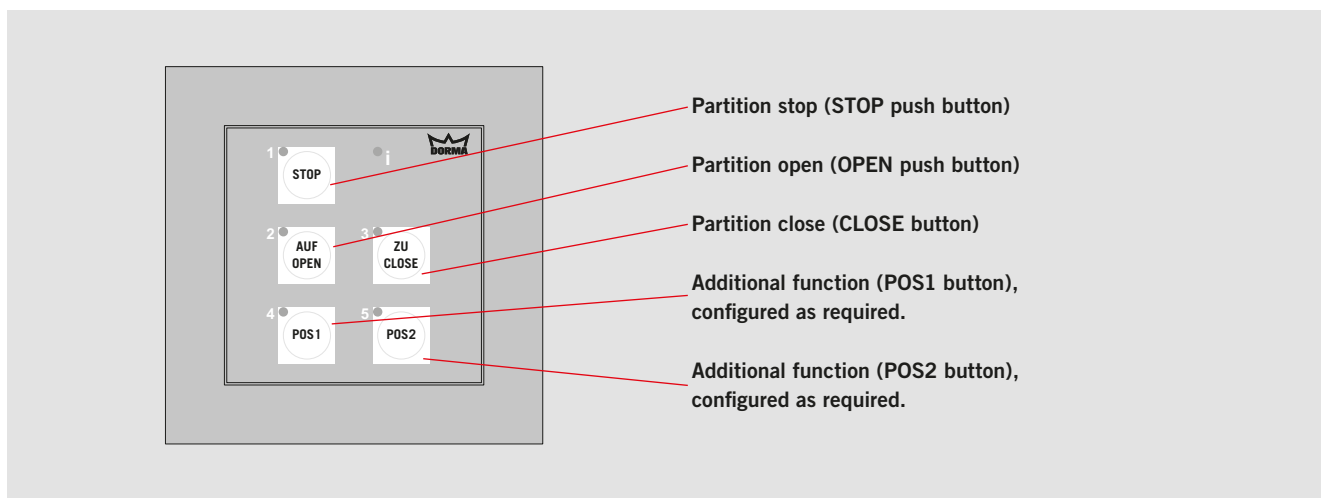

## COMMAND INPUT AT THE PUSH BUTTON PANEL

---

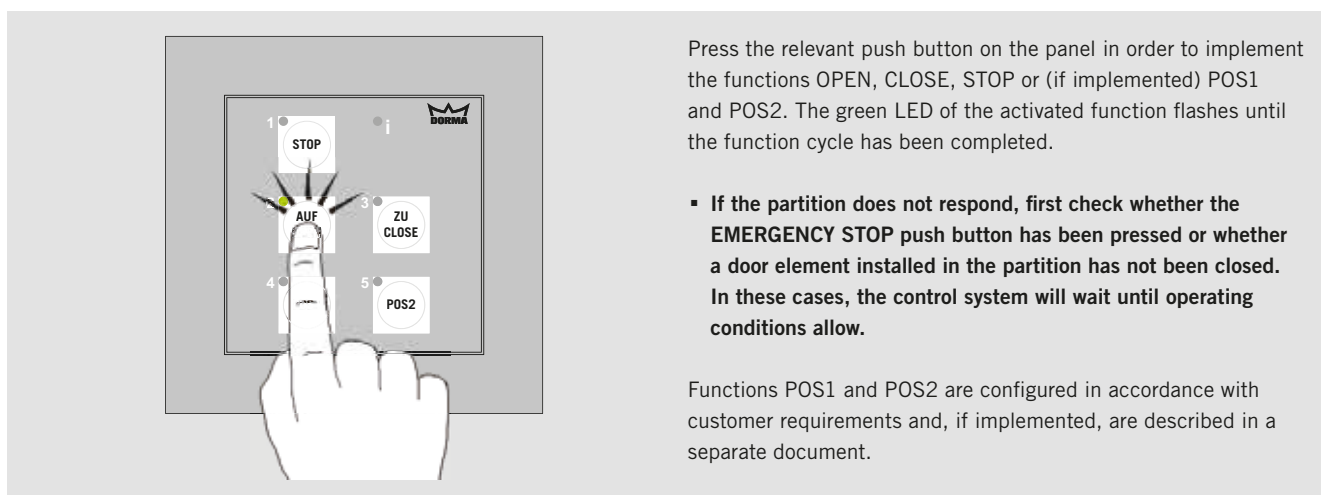

## SAFETY DEVICE

---

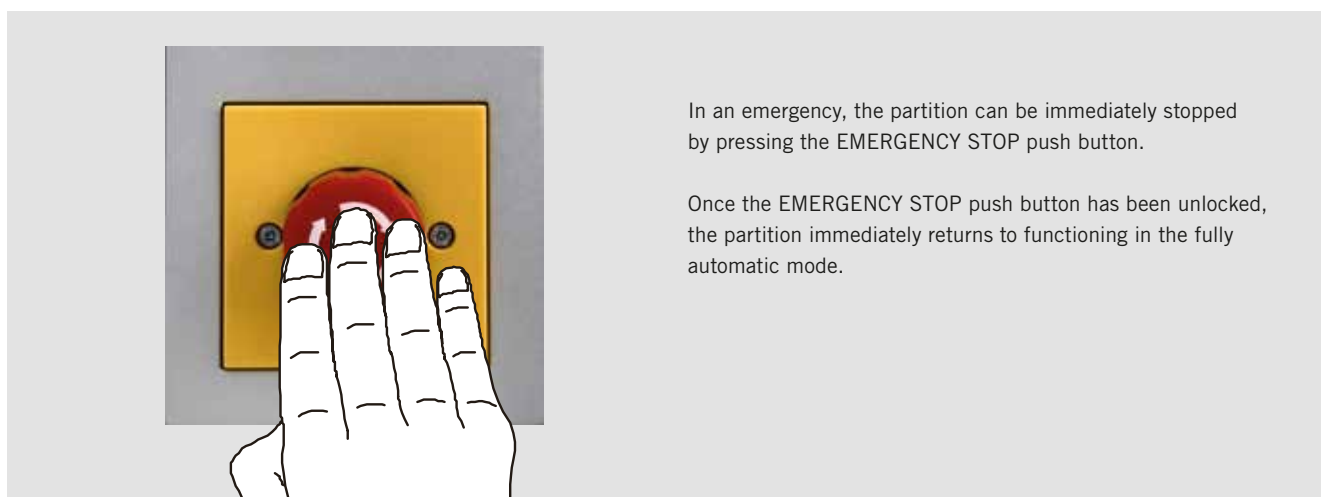

# FAULT DISPLAY IN THE EVENT OF A MALFUNCTION

If a fault occurs, the partition switches to fault mode and stops. The red LED on the push button panel then glows continuously.

Alternating flashing green LEDs indicate the fault code (aka error code). The first course of action should be to press the STOP push

button in order to cancel the fault. If the red LED lights up again, you will need to ascertain the fault code.

## Ascertaining the fault code

The green LEDs light up sequentially at intervals of 3 seconds. Next to each green LED is a number, and the sequence with

which the LEDs come on indicates a six-digit fault code. The fault code is repeated constantly at 5-second intervals. The

following illustration shows how the fault code 243121 is indicated. Fault code 243121 means "Obstruction – Element 5."

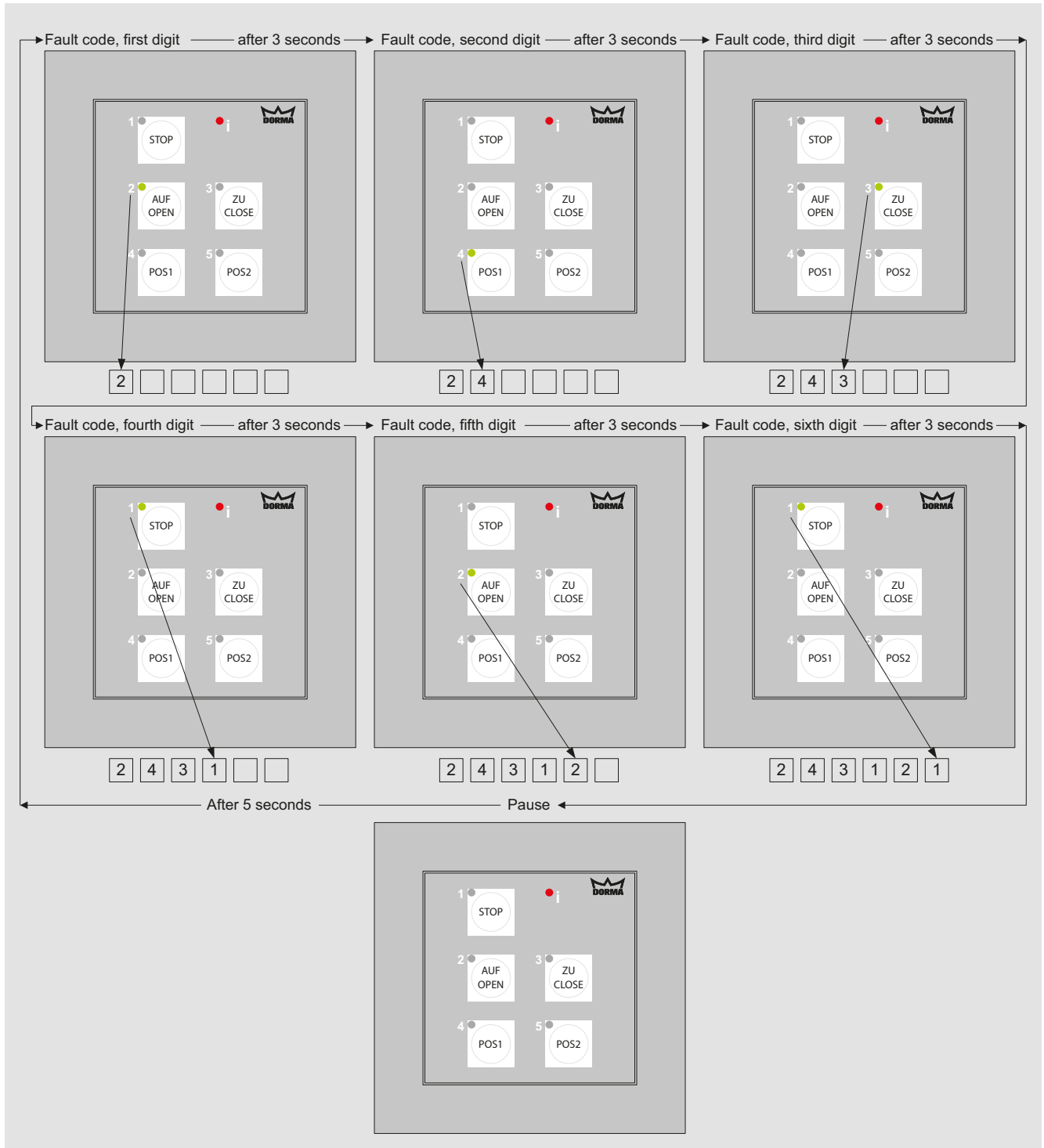

## TROUBLESHOOTING USING THE FAULT CODE

With some fault codes, you can find out the cause yourself. Below you will see a table of certain fault codes with the associated troubleshooting remedies. If the fault code indicated on the push button panel is not listed, or the remedy indicated does not have

the desired effect, please call our Customer Services. They will be able to carry out a detailed fault analysis on the basis of the fault code and initiate the necessary remedial activities.

The fault code consists of a six-digit numerical sequence which is repeatedly displayed after a 5-second pause. The fault code is divided into two groups of three digits:

Fault code:  $\begin{matrix} 1 & 2 & 3 & 4 & 5 & 6 \\ \mathbf{X} & \mathbf{X} & \mathbf{X} & \mathbf{Y} & \mathbf{Y} & \mathbf{Y} \end{matrix}$

Error code                      Component code

Fault code	Cause	Remedy
111	EMERGENCY STOP push button activated	Release the EMERGENCY STOP push button
131 143, 144, 145, 151, 152, 153, 154, 155, 211, 212, 213	Hardware defect	Operate the STOP push button to cancel the fault. If this does not have the desired effect, shut down the ComfortDrive partition control unit for 15 seconds. This work should only be done by an electrician or in-house technician.
243	Element obstructed	Use the component code to determine the element number (see below) and remove the obstruction from the travel path of that element.
244	Element positioning error	Open the partition by hand (see "Operating the partition in fault mode") and then press the OPEN push button in order to initialize the partition.
311, 433	An operable pass door is open	Close the operable pass door.
434	Extension of telescopic element (TE, only available with MOVEO and VERIFLEX) impeded by an obstruction	Remove the obstruction.
455	Stationary glass door (FTE) locked or bolted	Unlock and unbolt the stationary glass door (FTE).

### Component code YYY = Element number NN

Control unit	111 (exception: this component code means a control unit fault)							
Elements	112=01	113=02	114=03	115=04	121=05	122=06	123=07	124=08
Elements	125=09	131=10	132=11	133=12	134=13	135=14	141=15	142=16
Elements	143=17	144=18	145=19	151=20	152=21	153=22	154=23	155=24
Elements	211=25	212=26	213=27	214=28	215=29	221=30	222= All elements	

## OPERATING THE PARTITION IN FAULT MODE



If operating the partition by hand, make sure that the EMERGENCY STOP push button has been pressed!

### A. PARTITIONS WITH SINGLE-PANE GLASS ELEMENTS (VARITRANS OR HSW)

#### Opening the closed partition by hand

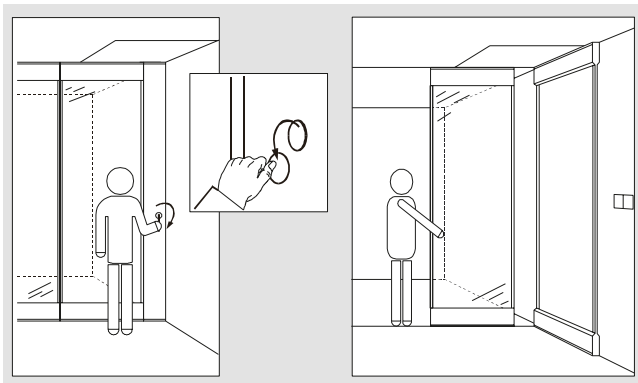

- If a wall flap (hinged abutment) is provided, remove the face cap covering the crank entry hole.
- Insert the crank and rotate in the direction of the arrow to unlock the wall flap. Then open the flap as you would a swing door.
- In the case of an electrically operated single-action door (if provided), simply disengage the lock using the security key provided and open the door manually.
- Move the elements at slow speed to the stacking area.



**In the case of partitions with element locking devices, unlock manually as described below!**

#### Manual unlocking of the partition

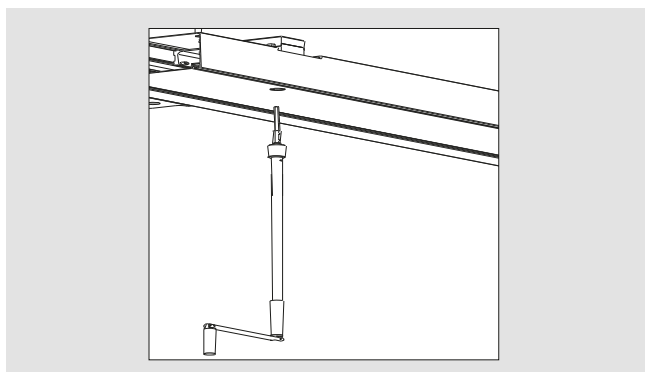

- Using the crank provided, undo the element locking bolt by winding out to its full length of travel (approx. 20 turns). The crank entry hole is located next to the overhead track to the left or right of the last element.



**Use crank carefully in order not to damage the locking mechanism!**

- The elements can then be pushed to the stacking area.



### Closing an open partition by hand

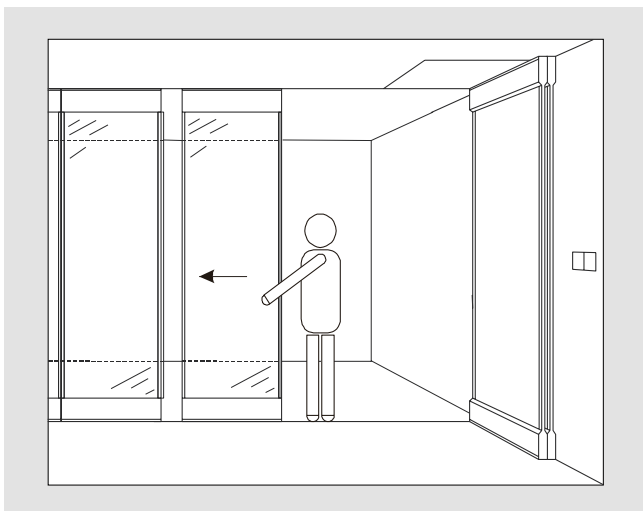

- Pull the elements at low speed from the stacking area to their end positions.
- Carefully press each element against the preceding element.
- In the case of partitions with a wall flap, swing the flap closed, insert the crank from the side into the wall flap hole and turn in the direction indicated by the arrow until the wall flap is locked.
- In the case of an electrically operated single-action door (if provided), the door merely has to be closed by hand. The door lock automatically engages and the partition is locked.



**In the case of partitions with element locking, the partition needs to be manually locked! See below.**

### Manually locking the partition

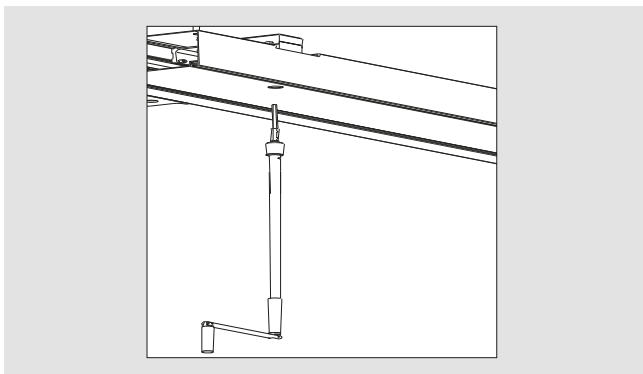

- Using the crank provided, rotate the element locking bolt by winding in to its full length of travel (approx. 20 turns). The crank entry hole is located next to the overhead track to the left or right of the last element.



**Use crank carefully in order not to damage the locking mechanism!**

- Pull the last element to determine whether the partition has been safely locked in position.

## B. PARTITIONS WITH SOUND-INSULATING ELEMENTS (MOVEO)

### Opening a closed partition by hand

In the event of a power failure, the ComfortDrive MOVEO® can be opened using the crank provided. For this, the sealing bars of the standard sliding

elements (VE) and the pass door elements (DT), and also the stroke unit of the telescopic element (TE) all need to be released using the hand crank.

Thereafter, push the elements (VE, DT and TE) at low speed from their end positions to the stacking area.

### Emergency operating points for the VE and TE elements (manual opening)

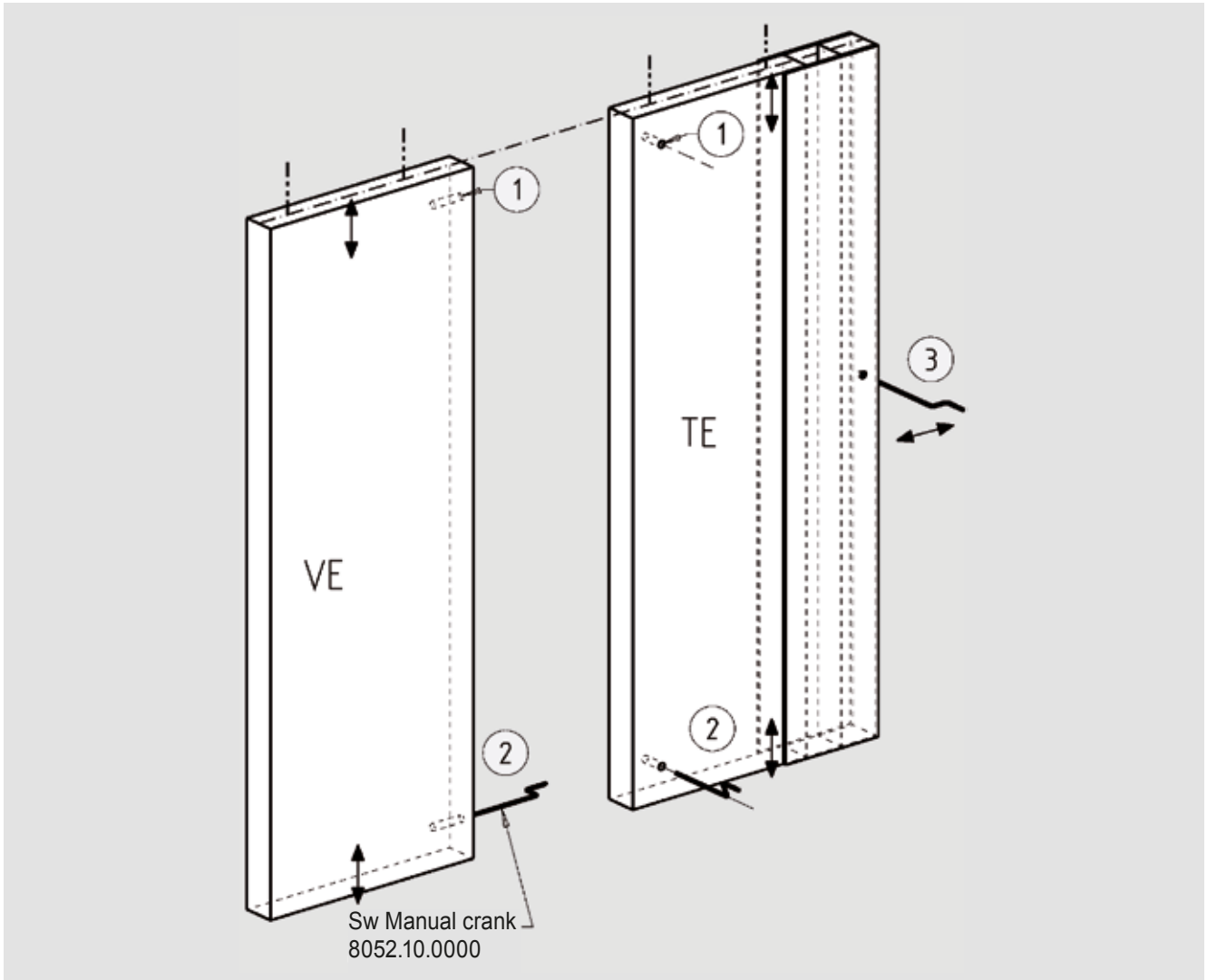

### Sequence for manual operation of the extending sealing bars

#### VE (open)

- 1 Release top sealing bar (1) (CCW)
- 2 Release bottom sealing bar (2) (CCW)

#### TE (open)

- 1 Release top sealing bar (1) (CCW)\*
- 2 Release bottom sealing bar (2) (CCW)\*
- 3 Release the stroke unit (3) horizontally (CW)

CW = clockwise rotation    CCW = counter-clockwise rotation

\* The direction of rotation relates to operation as illustrated. If the operation is carried out from the other side, the direction of rotation is reversed.

## Emergency operating points for DT (open)

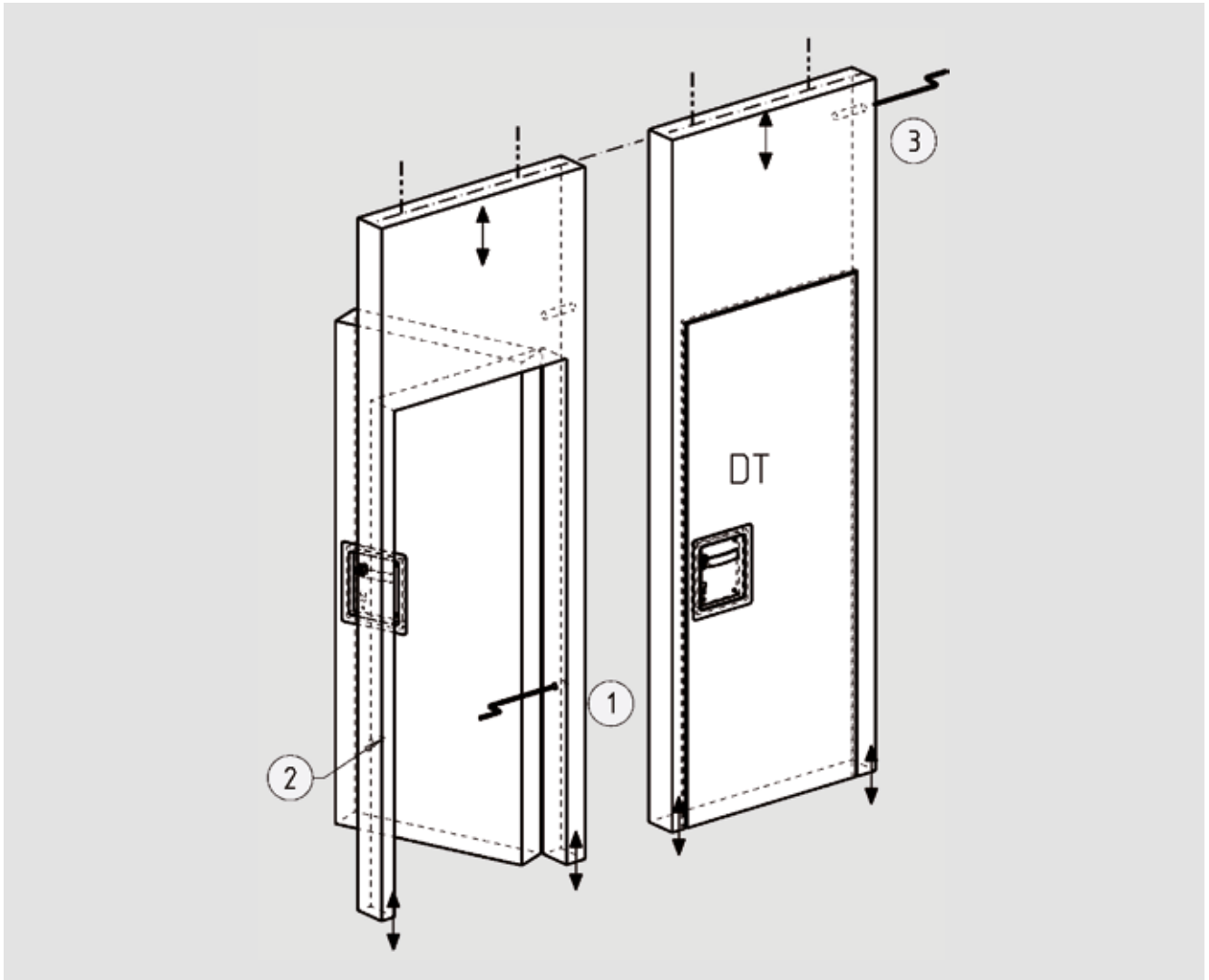

Leave the elements before and after the DT pass door element stationary for the moment so that the DT element does not move laterally when the door is opened. If there is no element behind the DT, secure the DT element in some other way to prevent it from moving sideways (risk of door leaf catching on the floor).

- 1 First open the leaf 90°.
- 2 Then release the sealing feet of the two door posts. The entry holes (1, 2) for the emergency crank are located in the frame area approx. 60 cm from the bottom. The direction of rotation is clockwise.
- 3 Then close the door leaf again and lock with the key.
- 4 Release the sealing bars of the element behind the DT pass door and push that element away.
- 5 Finally, release the sealing bar in the door element at the top (3) as in the case of standard sliding elements. The direction of rotation in this case is counter-clockwise.

## B. PARTITIONS WITH SOUND-INSULATING ELEMENTS (MOVEO)

### Closing an open partition by hand

In the event of a power failure, the ComfortDrive MOVEO® can be closed using the crank provided. For this, the elements (VE, DT and TE) will need to be pulled out of the stacking area

at low speed and moved into their end positions, ensuring that they are gently pressed against the preceding element. Thereafter, the sealing bars of the standard sliding elements

(VE) and the pass door elements (DT), and also the stroke unit of telescopic element (TE) can be secured in place using the crank.

### Emergency operating points for the VE and TE elements (manual closing)

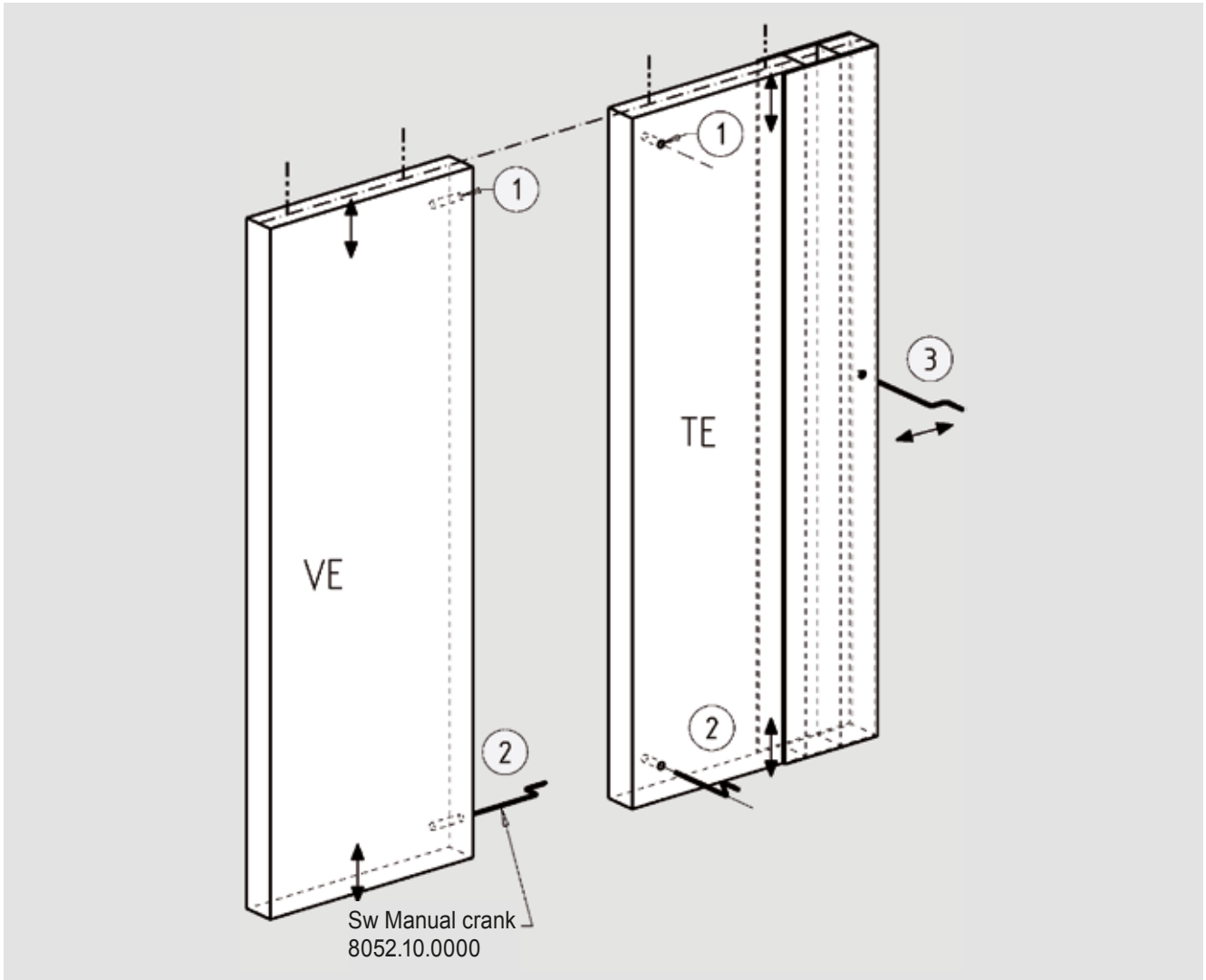

### Sequence for manual operation of the extending sealing bars

#### VE (close)

- 1 Engage top sealing bar (1) (CW)
- 2 Engage bottom sealing bar (2) (CW)

#### TE (close)

- 1 Engage stroke unit (3) horizontally (CCW)
- 2 Engage top sealing bar (1) (CW)\*
- 3 Engage bottom sealing bar (2) (CW)\*

CW = clockwise rotation    CCW = counter-clockwise rotation

\* The direction of rotation relates to operation as illustrated. If the operation is carried out from the other side, the direction of rotation is reversed.

## Emergency operating points for DT (close)

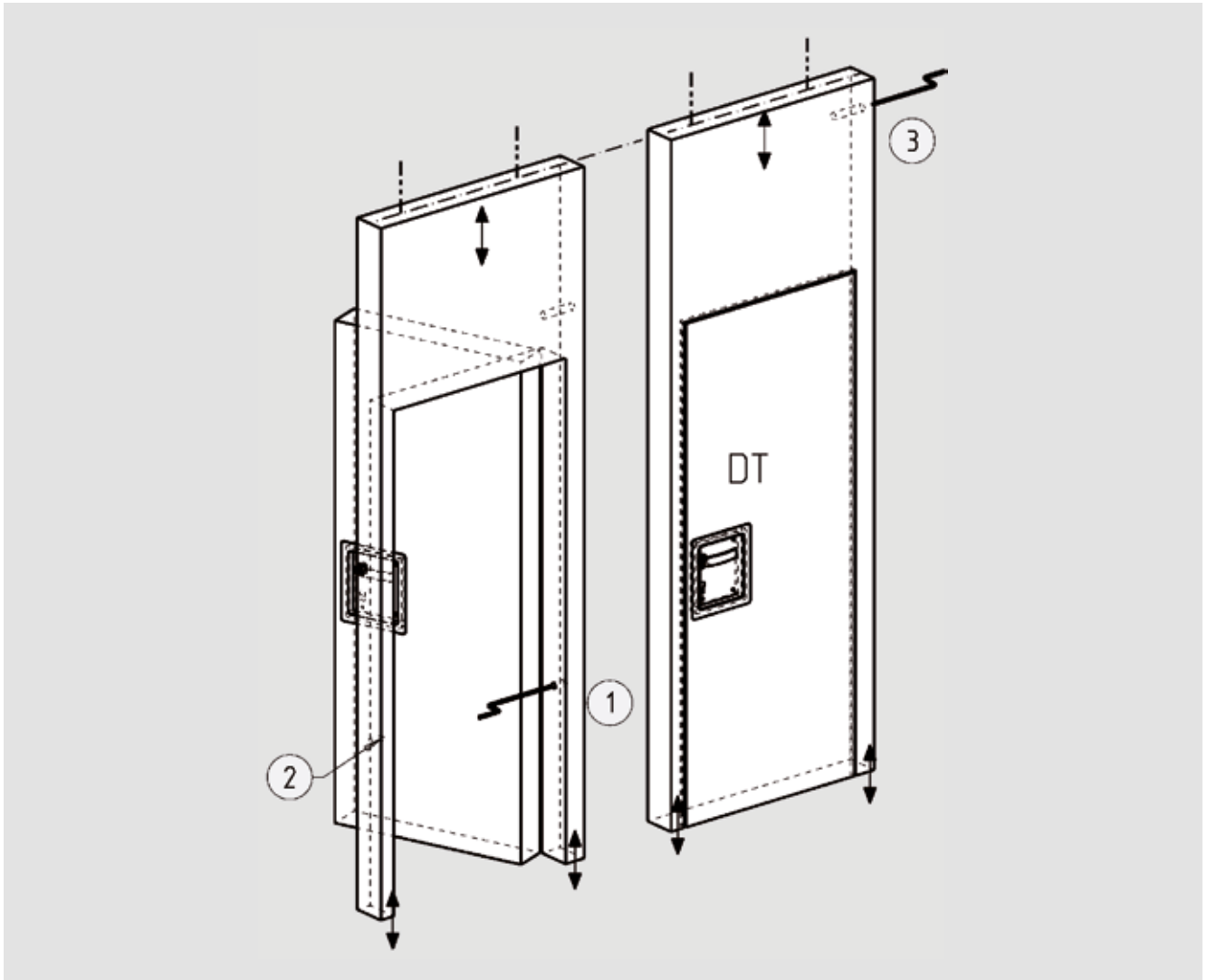

1 First engage the sealing bar at the top of the DT pass door element (3) as you would with a standard sliding element. The direction of rotation in this case is clockwise.

 Now immediately push the next element after the DT against the DT element and completely engage the

sealing bars of that next element so that the DT does not move laterally during the closing procedure. If there is no element behind the DT, secure the DT element in some other way to prevent it from moving sideways (risk of door leaf catching on the floor).

2 Open the leaf 90°.  
3 Then engage the sealing feet of the door posts. The entry holes (1, 2) for the emergency crank are located in the frame area approx. 60 cm from the bottom. The direction of rotation is counter-clockwise.

4 Now close the door leaf again and lock with a key where possible.

## C. PARTITIONS WITH SOUND-INSULATING ELEMENTS (VARIFLEX)

### Opening a closed partition by hand

In the event of a power failure, the ComfortDrive Variflex can be opened using the crank provided. For this, the sealing bars of the standard sliding elements (VE) and the pass

door elements (DT), and also the stroke unit of the telescopic element (TE) all need to be released using the hand crank. Thereafter, push the elements (VE, DT and TE) at low speed

from their end positions to the stacking area.

### Emergency operating points for the DT and VE elements (manual opening)

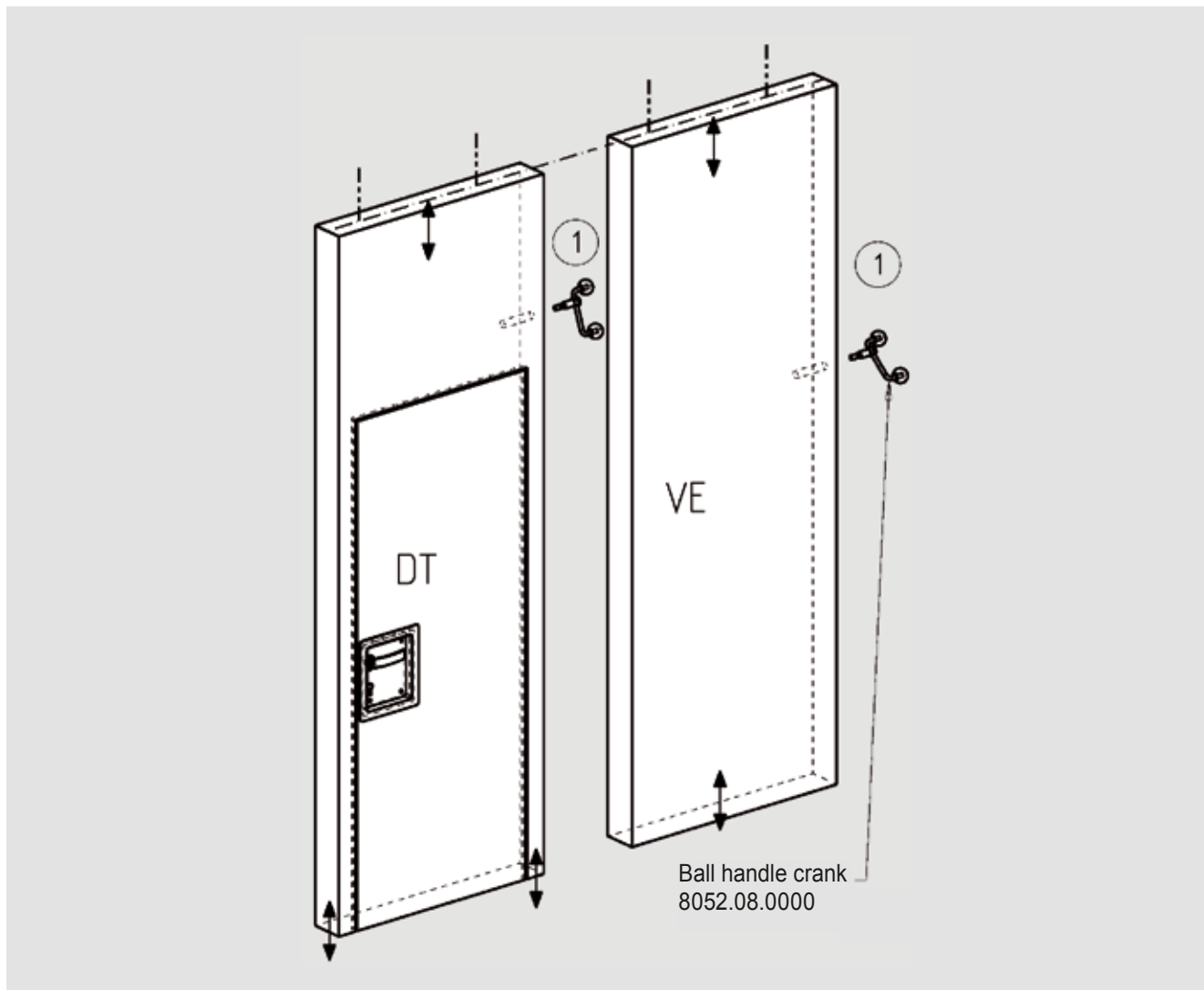

### Manual operation of the sealing bars

#### DT + VE (open)

Release sealing bars top and bottom (1) (CCW)

CW = Rotate in clockwise direction    CCW = Rotate in counter-clockwise direction

## Emergency operating points for TE (open)

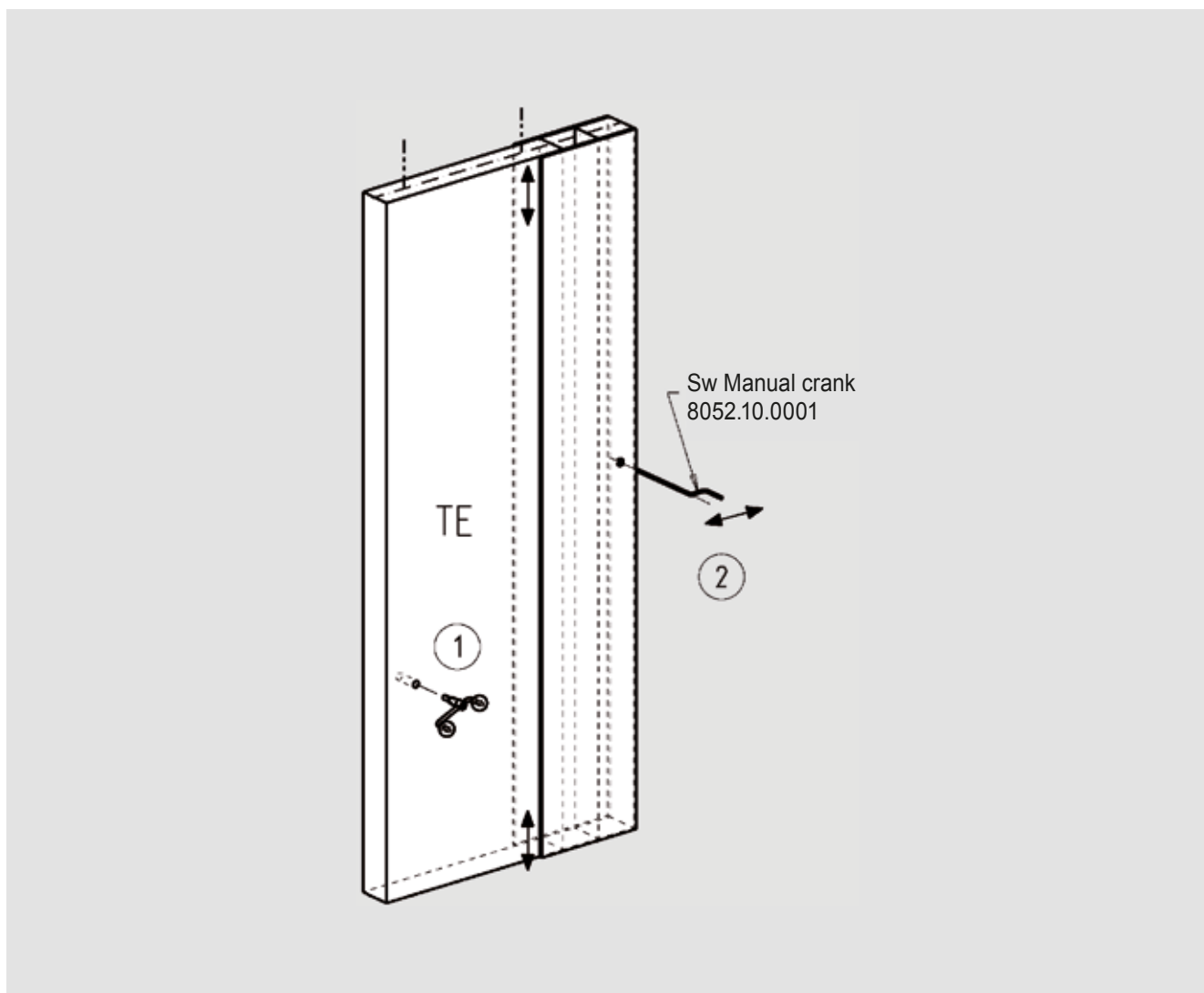

## Sequence of manual operation of the sealing bars

## TE (open)

- 1 Release sealing bars top and bottom (1) (direction of rotation as per label)
- 2 Release stroke unit horizontally (2) (CW)

CW = Rotate in clockwise direction    CCW = Rotate in counter-clockwise direction

## C. PARTITIONS WITH SOUND-INSULATING ELEMENTS (VARIFLEX)

### Closing an open partition by hand

In the event of a power failure, the ComfortDrive Variflex can be closed using the crank provided. For this, the elements (VE, DT and TE) will need to be pulled out of the stacking area at low

speed and moved into their end positions, ensuring that they are gently pressed against the preceding element. Thereafter, the sealing bars of the standard sliding elements (VE) and the

pass door elements (DT), and also the stroke unit of telescopic element (TE) can be secured in place using the crank.

### Emergency operating points for the DT and VE elements (manual closing)

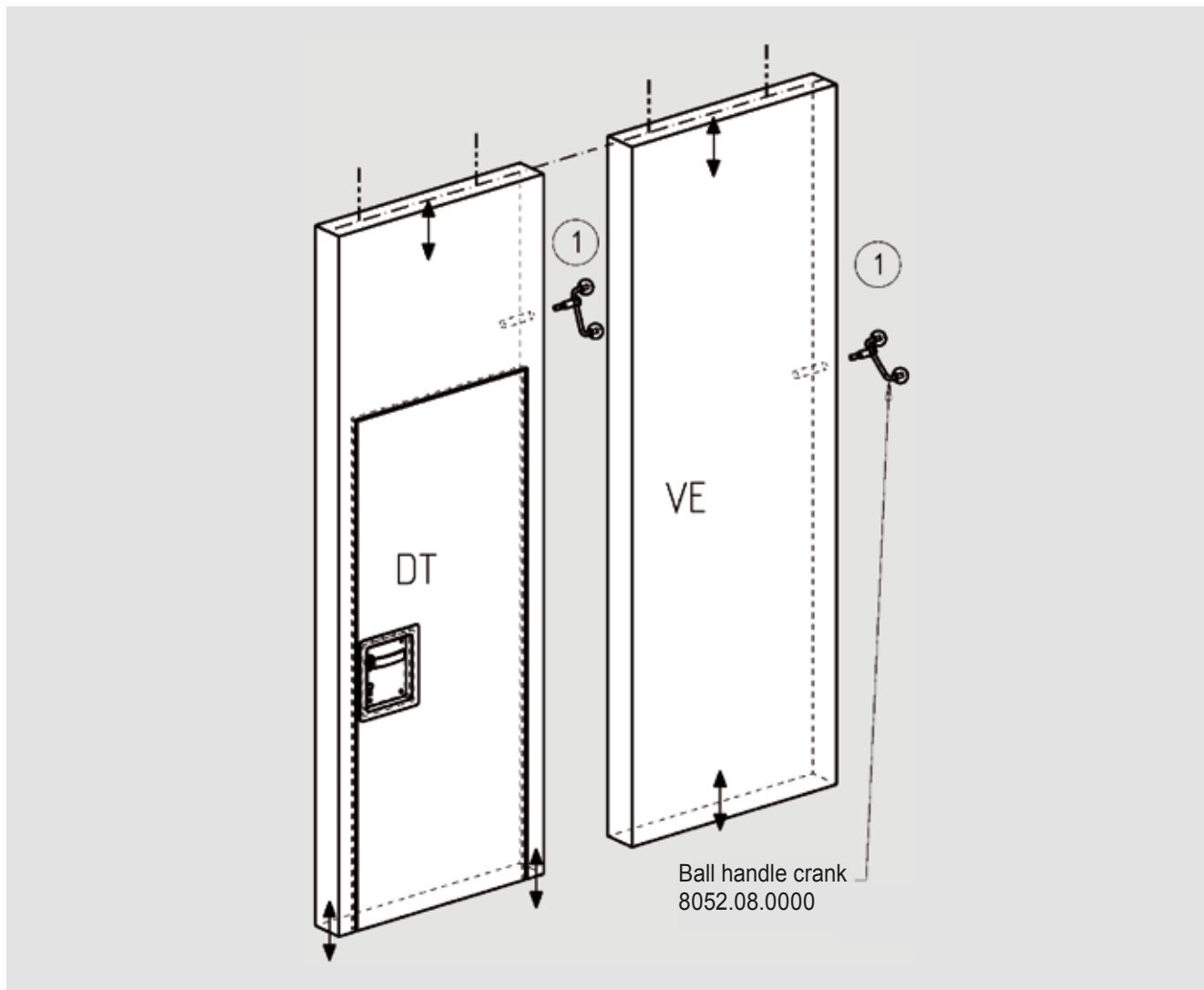

### Manual operation of the sealing bars

#### DT + VE (close)

Engage sealing bars top and bottom (1) (CW)

CW = Rotate in clockwise direction    CCW = Rotate in counter-clockwise direction



## Emergency operating points for TE (close)

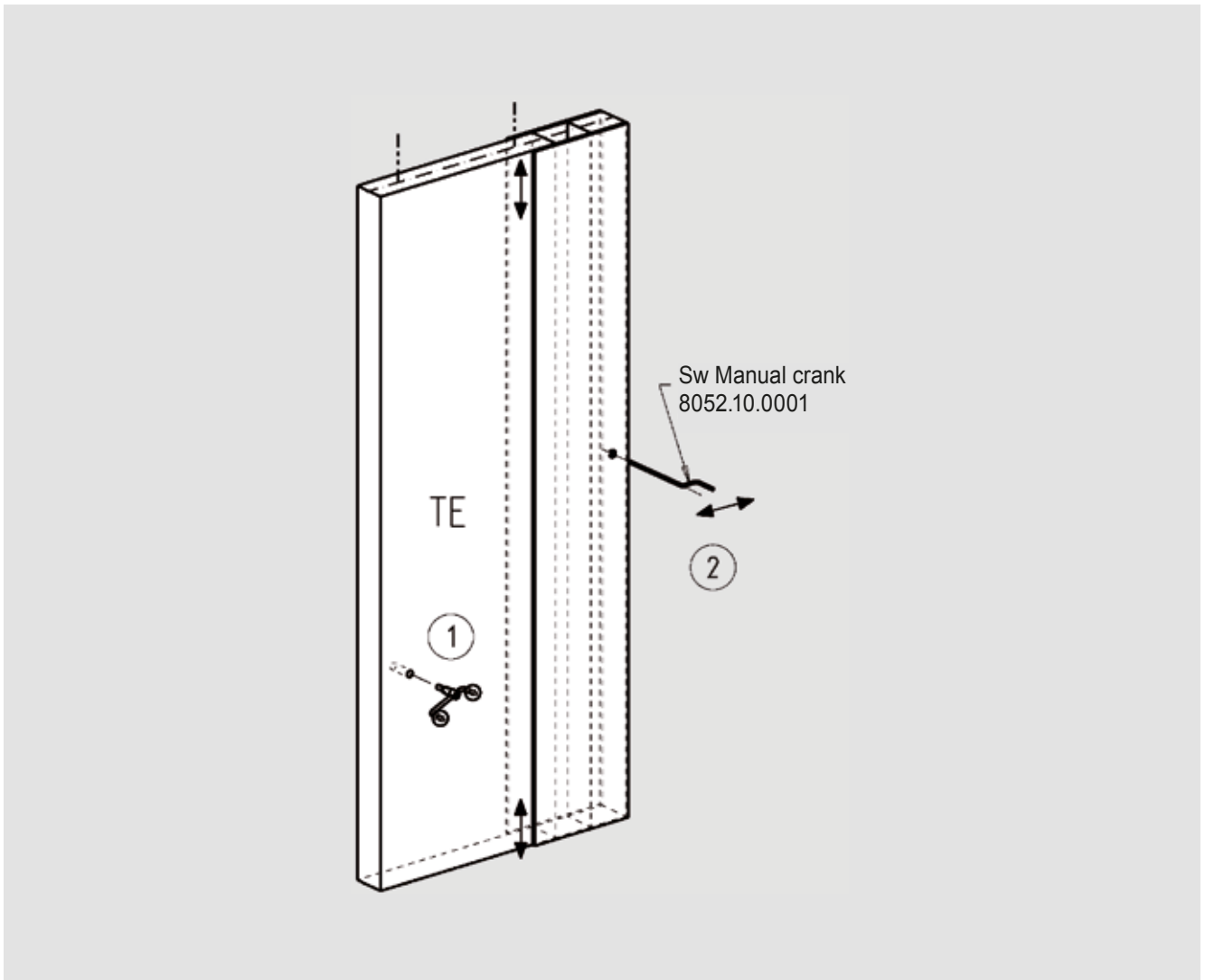

## Sequence for manual operation of the sealing bars

## TE (close)

- 1 Engage stroke unit (2) (CCW)
- 2 Engage sealing bars top and bottom (1) (direction of rotation as per label)

Rotate in clockwise direction    CCW = Rotate in counter-clockwise direction

## DORMA COMFORTDRIVE CARE AND UPKEEP

---

Make sure the floor track and sealing bars are regularly cleaned. To clean the elements, use only a soft, damp cloth with a mild liquid soap. Avoid droplet formation.

## MAINTENANCE AND REPAIRS

---

To ensure that the DORMA ComfortDrive continues to operate as it should, the system should be serviced at least once a year. We will be glad to offer you a maintenance contract for this annual service. This will

ensure the extensive avoidance of major malfunctions. And in the event of repairs, you can be sure that only original spare parts from the manufacturer will be used.

## DISPOSAL

---

The DORMA ComfortDrive system comprises various high-quality materials which can be recycled at the end of the partition's life. We recommend that you commission a specialist company experienced in this

field in order to ensure the correct disassembly and recycling of all system components.

## TROUBLESHOOTING

---

If the partition does not operate as expected, first look at the fault display on the push button panel as per the description starting on page 6. If the partition stops without any obvious reason, try to reinstate the required function by again pressing the appropriate push button.

If the partition still does not

move, first check whether all the required operating conditions are fulfilled, such as EMERGENCY STOP push button disengaged, power supply available, etc.

In the event of the line supply failing, the partition will stop immediately. If the partition needs to be moved while power is still unavailable, this can be

done manually as per the description starting on page 8. Once the power supply is reinstated, the partition will automatically switch to the STOP mode, allowing it to be operated using the push button controls as per the description starting on page 4. **(To bridge power supply failures, DORMA Hüppe Raumtrennsysteme can**

**also provide an uninterruptible power supply unit with which the system can continue to be operated as usual.)**

If all attempts to operate the partition in its automatic mode remain unsuccessful, please contact our Customer Services (for address, phone number and other contact details, please see the last page).

## TECHNICAL SPECIFICATIONS

---

Operator height	240 mm
Max. track length with one control unit	50 m
Max. number of elements	30
Element width	600 – 1500 mm
Max. element height	9000 mm
Max. element weight	500 kg
Radius (directional change)	150 mm
Hold-open time, personnel opening	adjustable
Travel speed	Dyn. up to max. 250 mm/s (weight-dependent)
Force limitation point	150 N
Power consumption in stand-by mode	45 VA
Max. power input (20 elements)	1 kVA
Average consumption (during operation of the element)	300 VA
Line fuse rating	max. 16 A
Power supply data	230 VAC
Power supply unit in operator	36 VDC
Class of protection	I
Air-borne sound emission	< 70 dB(A)



DORMA Hüppe  
Raumtrennsysteme  
GmbH + Co. KG  
Industriestraße 5  
26655 OCHOLT  
GERMANY  
Phone +49 4409 666-0  
Fax +49 4409 666-489  
info.hueppe@dorma.com  
www.dorma-hueppe.com  
**Service Hotline:**  
**0800 483 77 33**

DORMA CBP Schweiz AG  
Martingsbruggstrasse 85  
9016 ST. GALLEN  
SWITZERLAND  
Phone +41 71 282 82 82  
Fax +41 71 282 82 83  
info-cbp@dorma.com  
www.dorma-cbp.ch  
**Kostenlose Service-Hotline:**  
**0800 367 627**

DORMA Hüppe Austria GmbH  
Hollabernerstraße 4b  
4020 LINZ  
AUSTRIA  
Phone +43 732 600451  
Fax +43 732 650326  
office@dorma-hueppe.at  
www.dorma-hueppe.at  
**Service team:**  
**0043 732 600451**