

# MUTO Comfort L 1-flügelig Glasbearbeitung

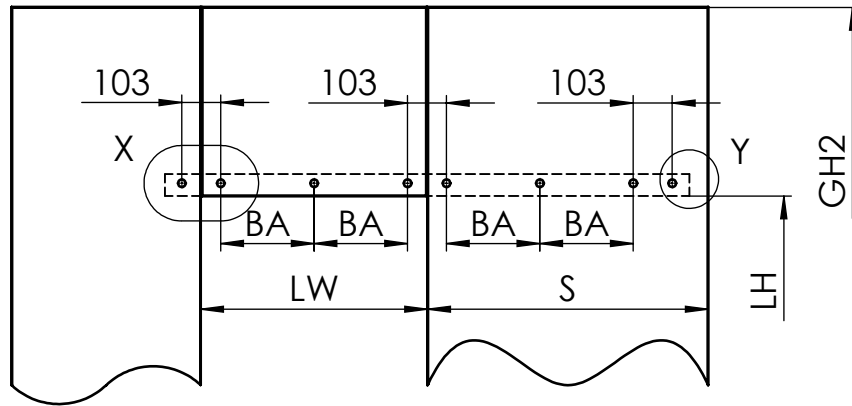

$A = LW + 60$
$B = 2 \times A + 67$
$BA^* = 2 \times (LW - 106) / T$

A	Flügelbreite	
AB	Anzahl der Bohrungen	
B	Laufschiene	
BA	Bohrungsabstand	
GH2	Glashöhe Seitenteil	
LH	lichte Höhe	
LW	lichte Weite	
S	Glasbreite Seitenteil	
T	Anzahl der Teilungen (BA*)	
	T	AB
	600 ≤ LW ≤ 800	4 8
	800 < LW ≤ 1000	6 10
	1000 < LW ≤ 1200	8 12
	1200 < LW ≤ 1500	10 14
	1500 < LW ≤ 2000	12 16

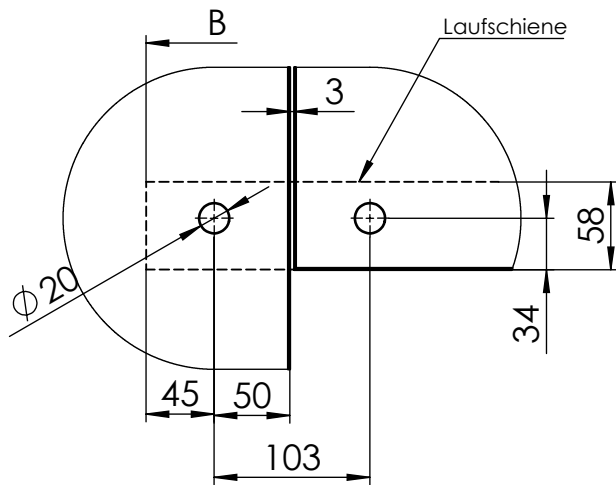

Detail X (1 : 5)

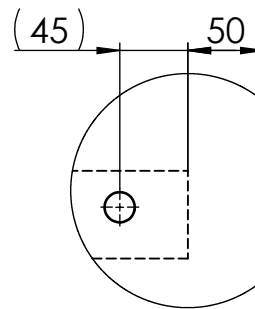

Detail Y (1 : 5)

	L 80	L DORMOTION 80
min. Flügelbreite ohne Dormotion:	660mm	660mm
min. lichte Weite ohne Dormotion	600mm	600mm
min. Flügelbreite mit Dormotion:	-	990mm
min. lichte Weite mit Dormotion	-	930mm
max. Flügelbreite:	2000mm	2000mm
max. lichte Weite	1940mm	1940mm
max. Flügelhöhe:	3000mm	3000mm
max. Flügelgewicht:	80 kg	80 kg
Glasdicke:	ESG/VSG 8 - 13,5mm	ESG/VSG 8 - 13,5mm
DORMOTION:	nein	Optional
getestet nach:	DIN EN 1527	DIN EN 1527

# MUTO Comfort L one door panel glass preparation

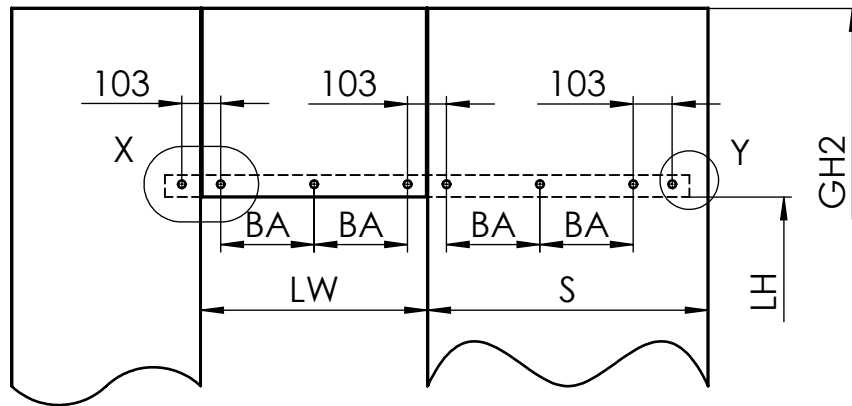

$A = LW + 60$
$B = 2 \times A + 67$
$BA^* = 2 \times (LW - 106) / T$

A	Glass width	
AB	quantity of drilling	
B	Length of track	
BA	Drilling distance	
GH2	Glass height Sidelight	
LH	Clear opening height	
LW	Clear opening width	
S	Glass width sidelight	
T	quantity of drilling distance (BA*)	
	T	AB
	600 ≤ LW ≤ 800	4 8
	800 < LW ≤ 1000	6 10
	1000 < LW ≤ 1200	8 12
	1200 < LW ≤ 1500	10 14
	1500 < LW ≤ 2000	12 16

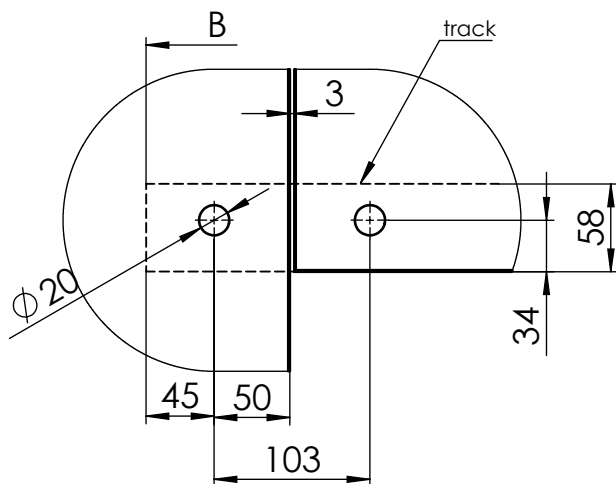

Detail X (1 : 5)

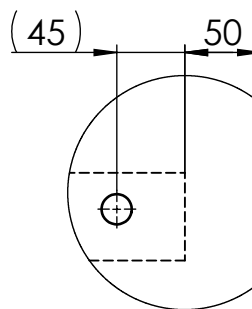

Detail Y (1 : 5)

	L 150	L DORMOTION 80
min. door width without Dormotion:	660mm	660mm
min. clear opening width without Dormotion:	600mm	600mm
min. door width with Dormotion:	-	990mm
min. clear opening width with Dormotion:	-	930mm
max. door width:	2000mm	2000mm
max. clear opening width:	1940mm	1940mm
max. door height:	3000mm	3000mm
max. door weight:	80 kg	80 kg
Glass thickness:	ESG/VSG 8 - 13,5mm	ESG/VSG 8 - 13,5mm
DORMOTION:	no	optional
performed to:	DIN EN 1527	DIN EN 1527