

DB25 INSTALLATION AND OPERATING INSTRUCTIONS

Before installation begins, please take note of the following;

- Four 10G x 1" Csk. Self-tapping screws are supplied for fitting the lock and strike plate. They are the suitable for mounting in both aluminum and wooden doors and frames.
- Ensure that a suitable power supply is used and that the power cables are of a sufficient gauge to eliminate any voltage drop at the lock.
- Do not fit the lock into a floor cavity firing upwards.
- Do not fit the lock in a 'wet environment' as evidence of water damage may void the warranty.
- Do not lubricate the lock. It has been lubricated when assembled and additional lubrication will void the warranty.

You will find the following items inside the box

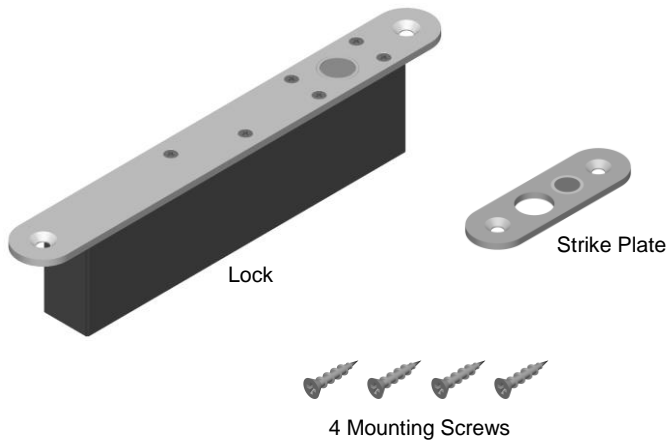

1 CUTTING MORTICES

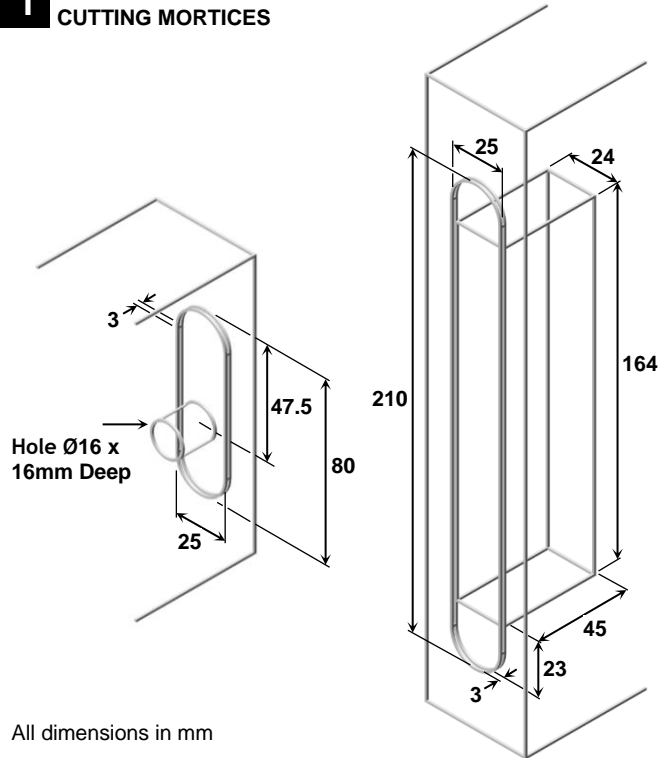

All dimensions in mm

Cut mortices into the door and door frame for the strike plate and lock as per the dimensions shown. The top end of the strike plate must be aligned with the top of the lock so the bolt pin goes centrally into the hole in the strike plate. The gap between the lock face plate and strike plate must not exceed 6mm when the door is closed.

2 WIRING THE LOCK

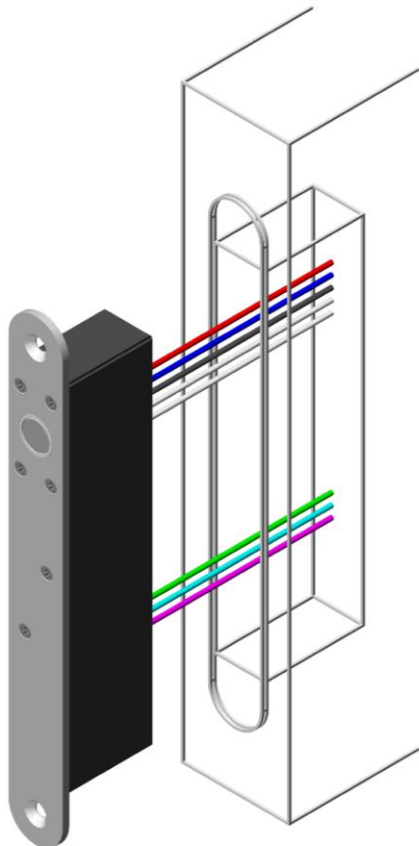

The wiring options and detail is shown overleaf. Once the desired wiring method is chosen run the wires into the rear of the mortice and connect to the lock. There are screw terminals for each wire and a connector guide is shown on the lock cover.

3 FITTING THE LOCK AND STRIKE PLATE

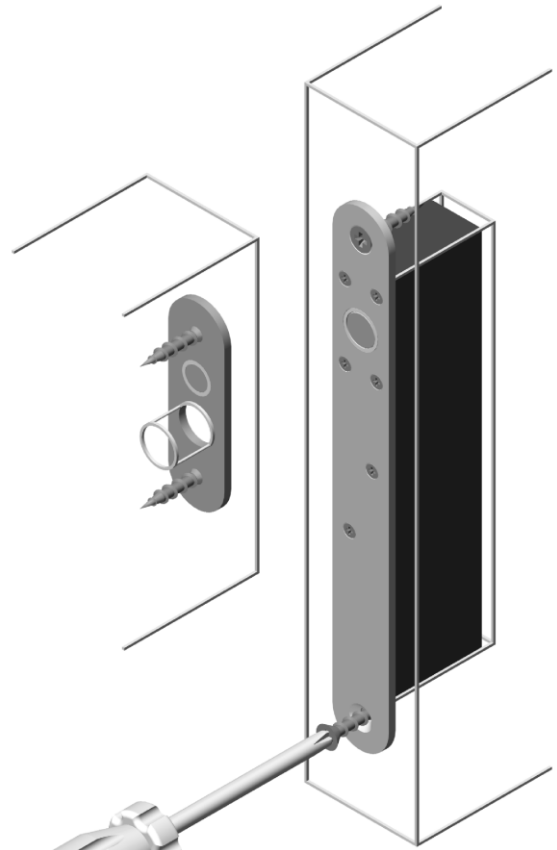

Slide the lock back into the mortice, making sure that the wiring integrity is maintained. Secure the lock and strike plate in place, using the supplied mounting screws. Ensure that the hole behind the strike plate is free from swarf and is deep enough to allow the lock pin to fully extend when locked.

DB25 INSTALLATION AND OPERATING INSTRUCTIONS

WIRING OPTIONS AND DETAILS

To utilize all available features the lock is fitted with eight connectors. Three are for power and control and five for monitors that provide bolt pin and door position information. The lock can be operated in two different modes; fully functioned **three wire mode** and reduced function **two wire mode**.

In addition to running the necessary wires for the desired mode, positioning the three dip switches located on the lock printed circuit board determines the operation. These are accessed by removing the cover.

Switches S1 and S2 are used to set the timed re-lock. If an unlock signal is given to the lock but the door is not opened the DB25 can automatically lock itself again after a selected time. This ensures that a door cannot be left unsecured if it has been unlocked but not opened. The timer is factory set to 9 seconds but 0, 3 and 6 second options are offered and selected by positioning the dip switches accordingly.

Switch M is used to select fail safe or fail secure mode. This is factory set as ordered and the **only time** it will need to be moved is when operating a fail safe lock in the two wire mode.

Markings S1,S2 and M are found on the printed circuit board.

FEATURES	3 WIRE MODE	2 WIRE MODE
Multiple re-lock (fail safe)	Yes 9x	Yes 5x
Multiple unlock (fail secure)	Yes 5x	Yes 5x
Auto re-lock	Yes	Fail safe only
Anti-Tamper	Yes	Yes
Fail Safe – dip switch 3	Off	On
Fail Secure – dip switch 3	On	On
Adjustable timed re-lock	Yes	No

TIMER	SWITCH POSITIONS
0 second timed re-lock	S1 On & S2 On
3 second timed re-lock	S1 Off & S2 On
6 second timed re-lock	S1 On & S2 Off
9 second timed re-lock	S1 Off & S2 Off

Three wire mode

The three wire mode requires a continuous connection of power to terminals 1 (+ve) and 3 (-ve). Wiring the lock for fail safe or fail secure configurations is identical.

Fail safe operation; momentarily connecting '1' to '2' unlocks the door for a period of 9 seconds. After the 9 seconds has elapsed if the door has not been opened the DB25 automatically locks again. If the door has opened and closed within the 9 second window (which is the case in normal operation) the unlock delay is overridden and automatic relocking occurs as soon as the door is closed. On closing, full power is applied to the DB25 9 times in 15 seconds before the current is reduced and lock goes into a holding mode to minimize heating and power consumption.

Fail secure operation; momentarily connecting '1' to '2' unlocks the door and over a 9 second period full power is applied to the lock 5 times. If the door remains closed, after 9 seconds has elapsed the DB25 automatically locks again. If the door has opened within the 9 second window (which is the case in normal operation) the DB25 will remain unlocked and in a holding mode until the door is closed again and automatic re-locking occurs.

In either fail safe or fail secure configuration, maintained connection of '1' to '2' will keep the DB25 unlocked regardless of door position.

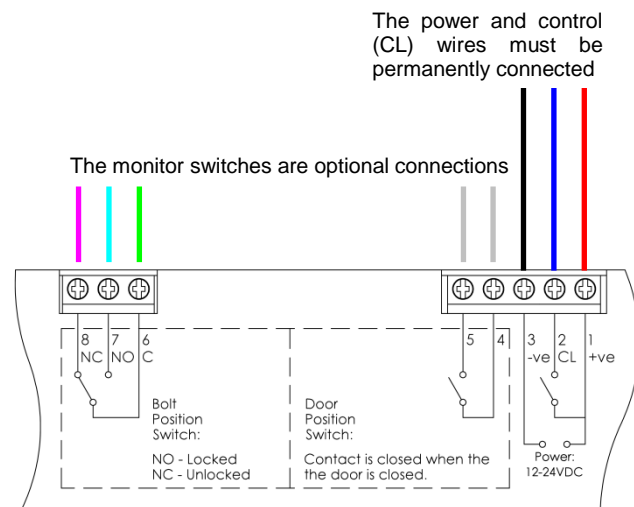

Two wire mode

The two wire mode differs between fail safe and fail secure but both require a switched supply connected to terminals '1' and '3'. In addition, for fail safe configuration the jumper needs to be repositioned as shown above.

Fail safe operation; a link is connected between terminals '2' and '4' and also between '1' and '5'. The lock will remain unlocked with power switched off. With power applied, and with the strike plate correctly aligned, the DB25 locks. As long as the door is open the DB25 will remain unlocked.

Fail secure operation; a link is connected between terminals '1' and '2'. The DB25 will be locked when no power is applied and will unlock when power is applied. The operation remains the same regardless of door or strike plate position.

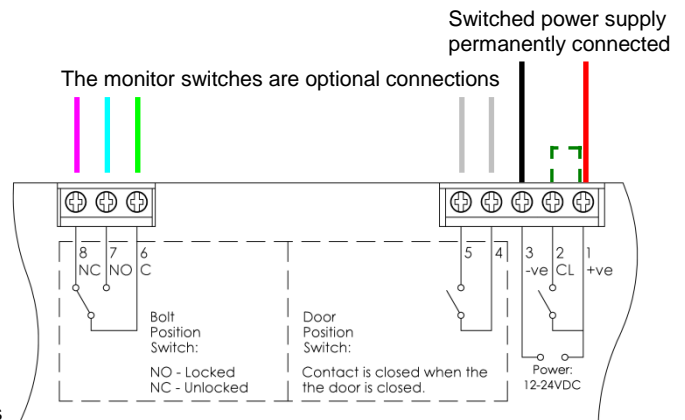
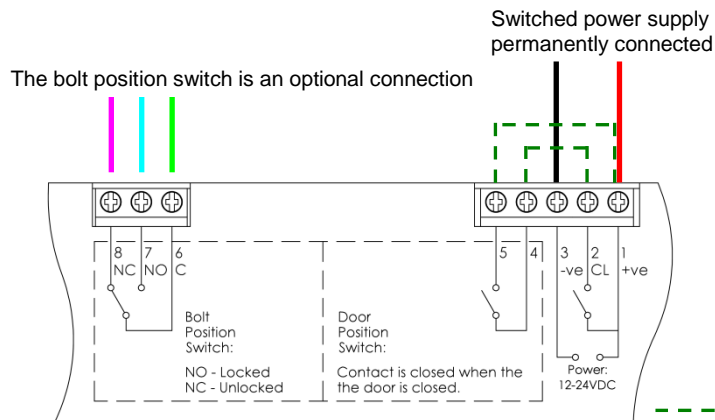

For more information visit
www.dormakaba.com.au
www.dormakaba.co.nz