



950/951 Series Mortice Locks Installation Instructions

PREPARE DOOR

Cut opening in door to suit cover plate and drill holes to suit function required.

Drill 2 holes
4 Dia. & C'sink
6 Dia. x 90° Incl.

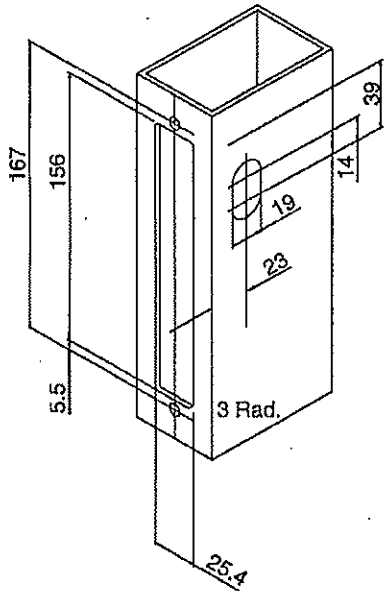

CYLINDER

or

TURN KNOB

CYLINDER ASSEMBLY

Attach cylinder assembly and secure with clamp screw supplied. Ensure clamp screw is fully inserted to firmly anchor cylinder assembly. Fit cylinder trim assembly.

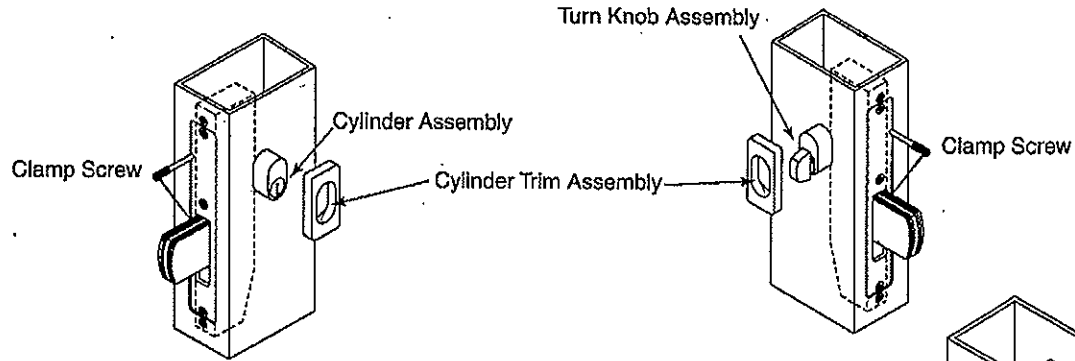

TURN KNOB ASSEMBLY

Attach turn knob assembly and secure with clamp screw supplied. Ensure clamp screw is fully inserted to firmly anchor turn knob assembly. Fit cylinder trim assembly.

CUT BOLT HOLE

Cut a bolt hole in door jamb as shown.

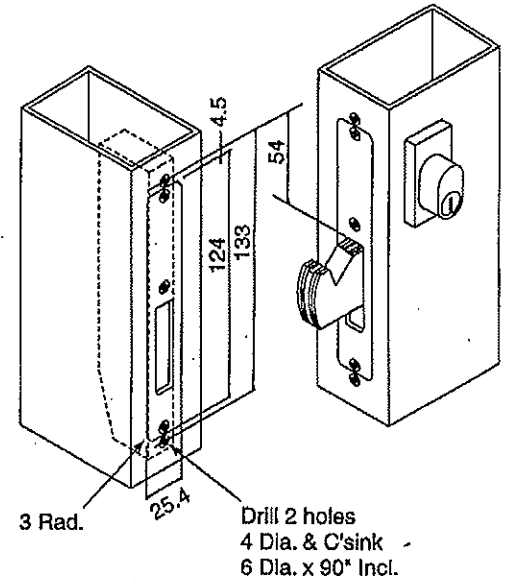

COVER PLATE

Attach cover plate to lock with 3 C'sunk head screws (5mm long) supplied.

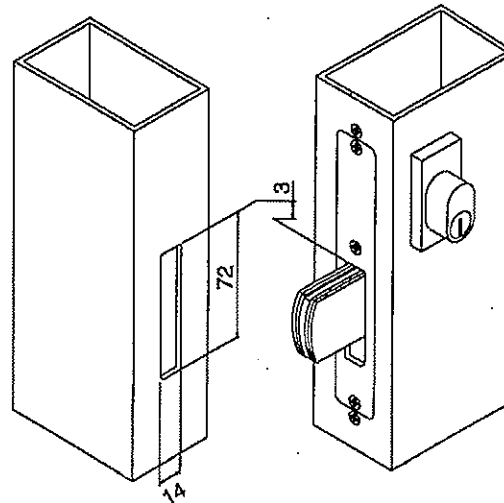
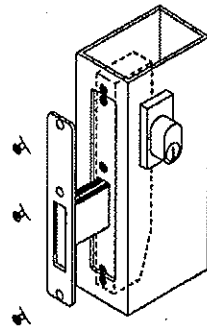

FIT SLIDING DOOR STRIKE

Cut opening in door jamb to suit strike plate and drill holes as shown. Fit strike assembly into door jamb and secure with 2 C'sunk head screws (6mm long) supplied and attach strike cover.