

Headers - 4-1/8", 4-1/2", 6"
with RTS88 for single or double doors

Installation instructions

933830 – 03-2017

| EN |

dormakaba 

Table of contents

1	Technical specifications	3
1.1	Overview	3
1.1.1	General information	3
1.1.2	Intended use	3
1.1.3	Glass requirements/fittings/mounting	3
1.1.4	Requirements for glass panel	3
1.1.5	Safety instructions	3
1.1.6	Symbols used - Safety/Installation	3
1.1.7	Maintenance, care, repair	3
1.1.8	Disposal	3
2	Installation instructions	4
2.1	Install header for single or double door: RTS88	4
2.2	RTS88 adjustments	5

1 Technical specifications

1.1 Overview

Follow these instructions in addition to the mounting and operating instructions in order to avoid damage of product and damage of person or property.

These instructions are for installation of 4-1/8", 4-1/2", and 6" headers for the following mounting and style versions:

1. Glass mounting

1.1.1 General information

- dormakaba requires use of tempered laminated or monolithic glass.
- dormakaba glass hardware is not suitable for harsh environments; for example, applications where chemicals (e.g. chlorine) are used such as indoor swimming pools, saunas, or salt-water pools.
- Do not swing doors with excessive force. Install limiting stop to prevent door from opening too far.

1.1.2 Intended use

- To house the RTS overhead concealed closers and other pivot options.

1.1.3 Glass requirements/fittings/mounting

- The substructure/wall must be able to bear permanent loads, be level (max. tolerance: 1/16" [2mm] per meter).
- Fixings must be sufficiently dimensioned for the substructure/wall and weight of the door.
- When adjusting glass elements, always stick to the required clearance for the respective hardware. Adjust clearance so glass does not come in contact with any hard surfaces such as glass, metal or concrete.
- Do not use excessive force when installing the glass (avoid over tightening screws.)

1.1.4 Requirements for glass panel

- Heat-soaked thermally tempered safety glass
- Clamping area must be flat and uncoated (no self-cleaning coating!)
- Never use glass with conchoidal fractures and/or damaged edges.

1.1.5 Safety instructions

- Installation requires two people.
- Always wear protective clothing.
- Only properly qualified and specially trained staff is authorized to mount dormakaba glass hardware.
- Due to crushing hazards and possible injury caused by breakage of glass during mounting, corresponding protective clothing (especially gloves and protective goggles) is required.
- Never clamp metal glass fitting hardware directly to glass surface.
- Never use clamping roller carriers on self-cleaning coatings.

1.1.6 Symbols used - Safety/Installation



CAUTION

Mounting components must meet the requirements of substructure/wall and door weight. Please read the technical information for fittings.



WARNING

Risk of breaking glass. When installing the door, support the door panel with a block of wood or similar object.



TIPS AND RECOMMENDATIONS

Information note

1.1.7 Maintenance, care, repair

- Immediately replace damaged parts.
- Always use original dormakaba parts.
- Clean clamping area with alcohol-based standard commercial cleaning agent before mounting the glass hardware.
- Use a damp clothe for occasional cleaning, especially the track.
- Always use silicone - and oil-free cleaners (e.g. acetone).
- Check glass hardware at regular intervals for proper positioning, smooth operation and correct adjustment.
- High traffic door systems require inspection by properly qualified staff (specialized companies or installation firms.)

1.1.8 Disposal

Disposal in accordance with local, state and national regulations.

2 Installation instructions

2.1 Install header for single or double door: RTS88

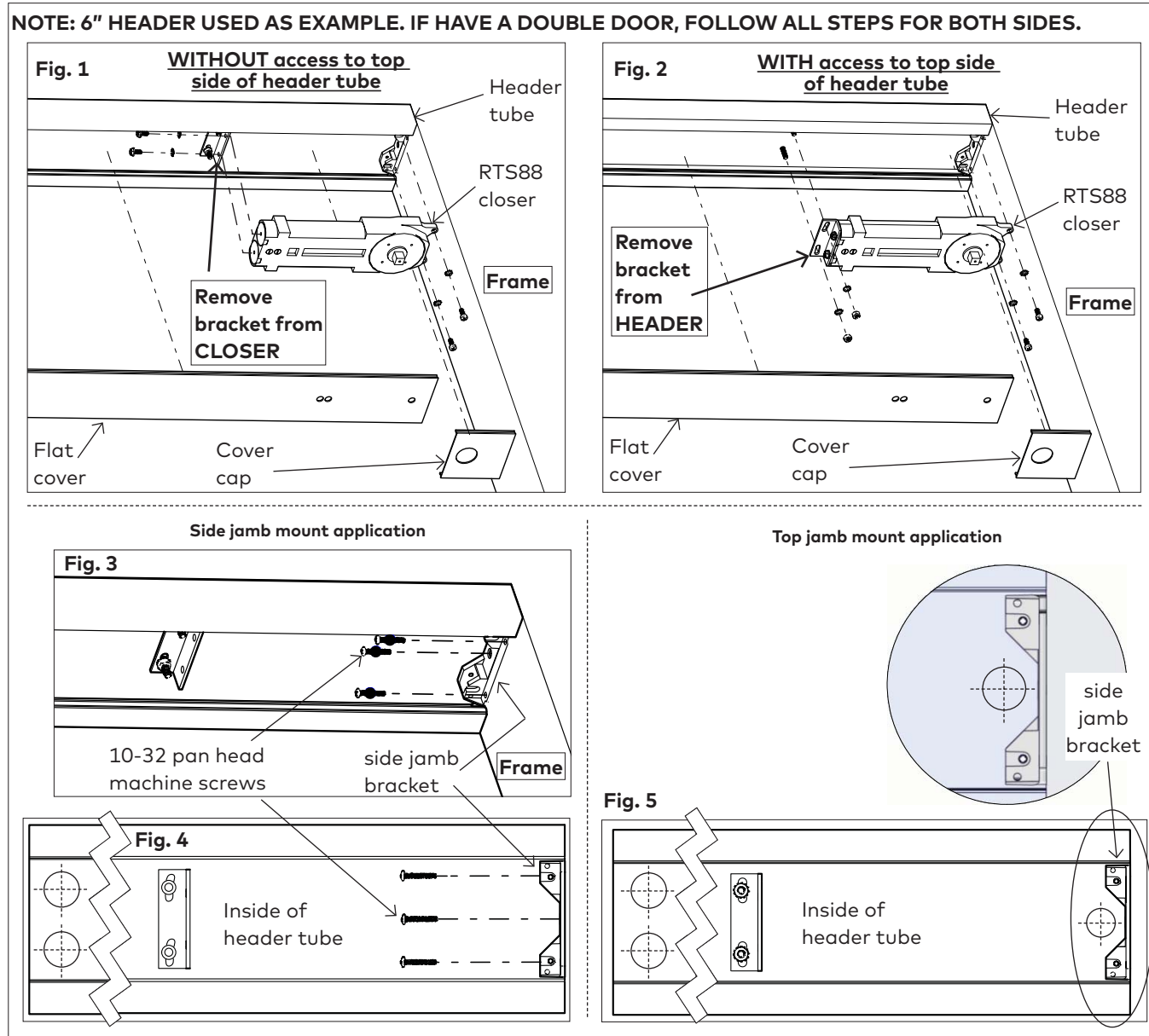

2.1.1 Remove covers and closer from header tube **dependent upon access to top side of header tube.** Figures 1 & 2.

2.1.2 Pre-drill holes and secure header tube using appropriate fasteners dependent upon application: side jamb or top jamb mount:

2.1.2.1 Side jamb mount:

- Secure frame to side jamb bracket using three 10-32 pan head machine screws [#10 pan head wood screws]. Figures 3 & 4.
- And secure header to overhead frame using appropriate fasteners. Figure 4.

2.1.2.2 Top jamb mount: Figure 5.

- Secure header to overhead frame **only**, using appropriate fasteners.

NOTE: Always ensure the proper fasteners and adequate number of fixing points for your specific field conditions.

2.1.3 Resecure RTS88 closer inside header tube using included fasteners.

2.1.4 Adjust closer if necessary. See adjustments section: 2.2

2.1.5 For double door applications, follow steps 2.1.1 through 2.1.5.

2.2 RTS88 adjustments

Fig. 6 RTS closer

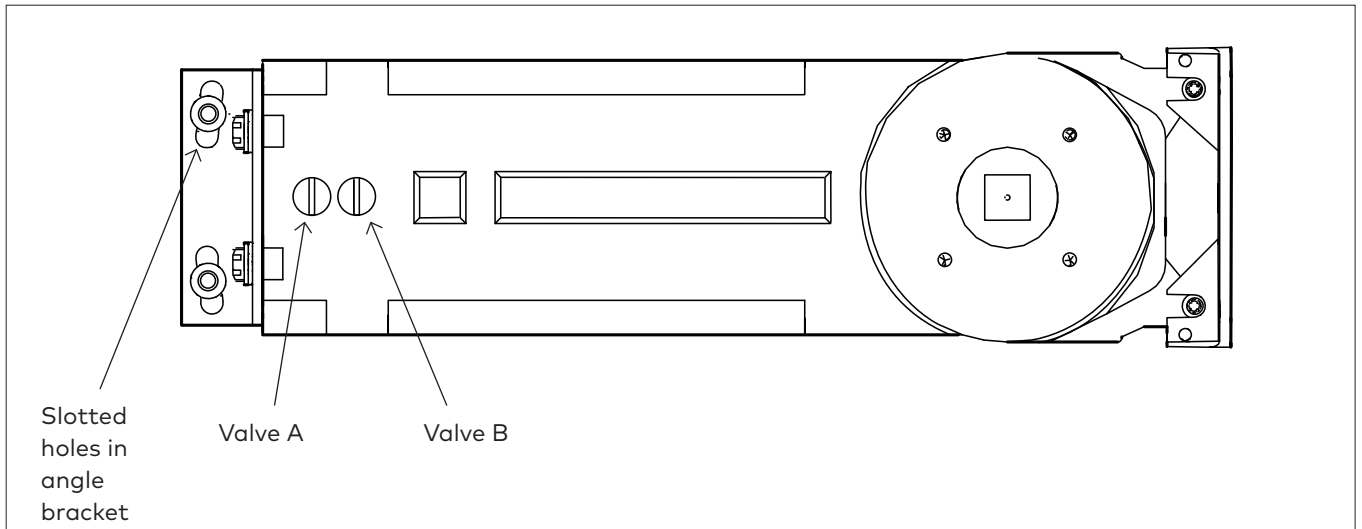

- 2.2.1 Ensure closer is plumb and level.
- 2.2.2 Adjust via slotted holes in angle bracket prior to fully tightening screws.

- Valve "A" - Closing/sweep speed - from maximum opening to 0°.
 - Clockwise** - decrease closing speed
 - Counter-clockwise** - increase closing speed
- Valve "B" - Latch speed - from maximum opening to 20°.
 - Clockwise** - decrease closing speed
 - Counter-clockwise** - increase closing speed

