

# Installation Instructions

## 7471K Center Hung Floor Bearing

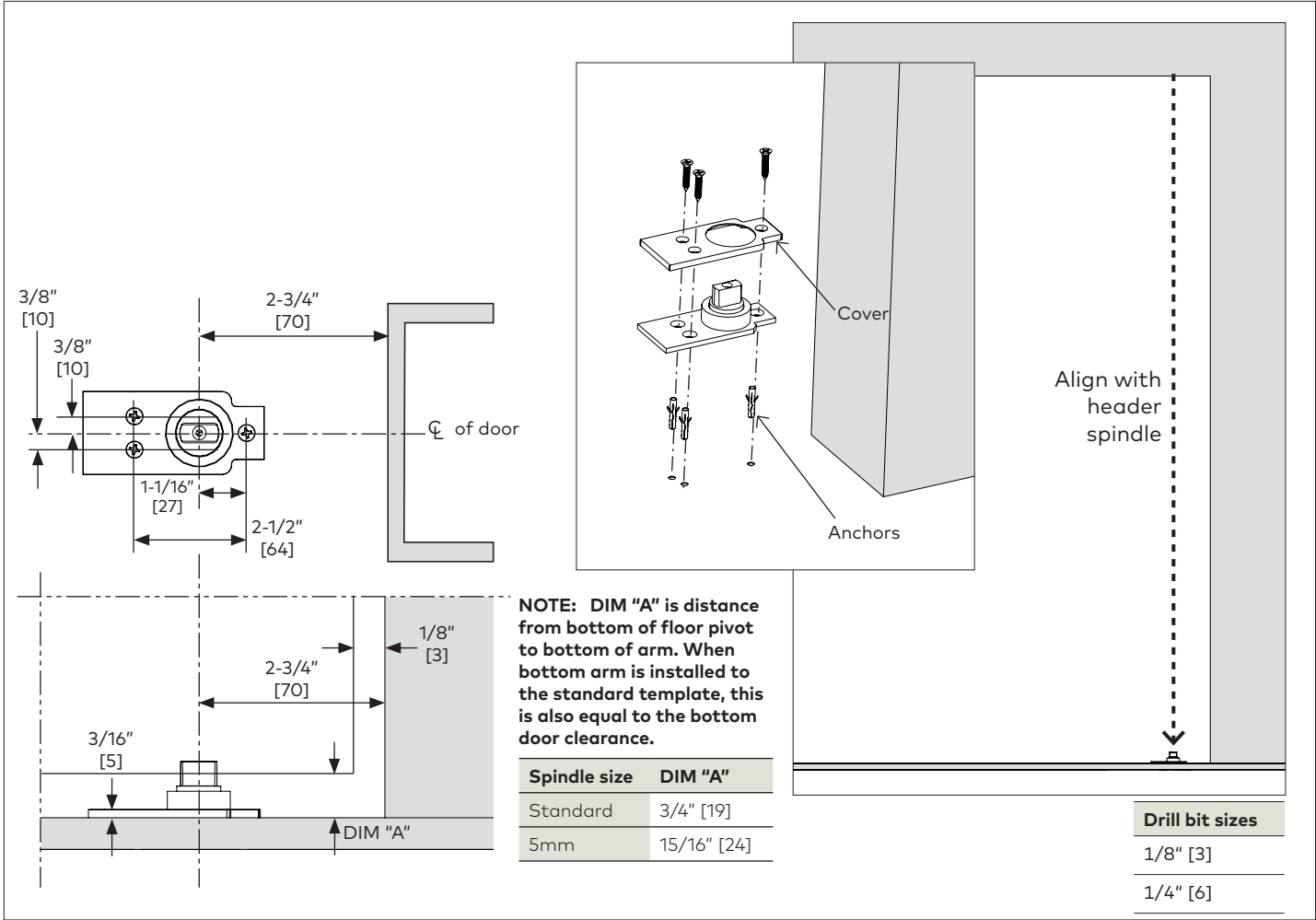

- 1.1 Using a plumb bob, align header spindle with bottom pivot spindle.
- 1.2 Mark and drill holes in flooring surface.
  - Wood Floors: 1/8" [3] drill bit.
  - Concrete Floors: Drill 1" [25] deep holes, using 1/4" [6] drill bit.
- 1.3 Insert anchors, if necessary.
- 1.4 Ensure pivot is aligned and plumb.
- 1.5 Secure floor bearing and cover using included fasteners.

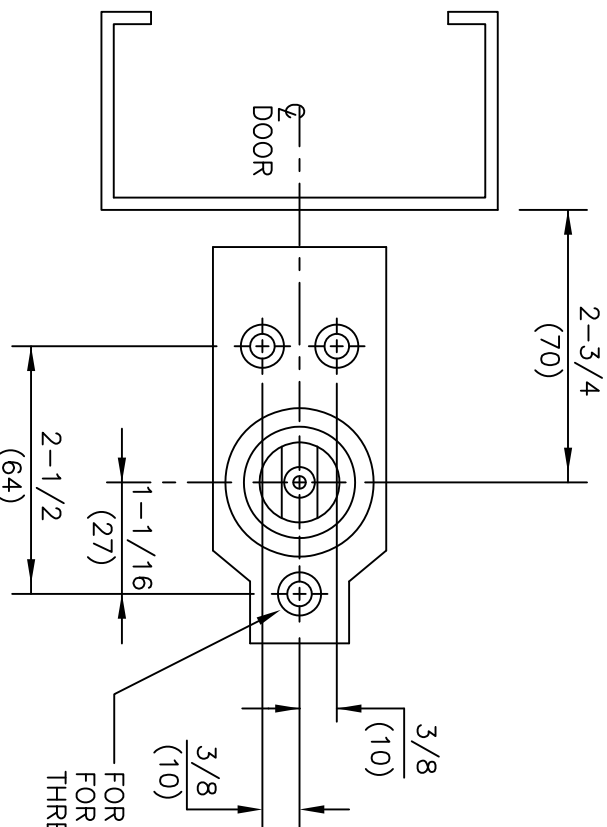

FOR WOOD FLOORS USE 1/8" DRILL  
 FOR CONCRETE FLOORS USE 1/4" DRILL 1" DEEP  
 THREE (3) HOLES

- NOTES:
1. DO NOT SCALE DRAWING.
  2. DIMENSIONS ARE IN INCHES\MM.
  3. DIMENSION "A" IS DISTANCE FROM BOTTOM OF PIVOT TO BOTTOM OF ARM. WHEN BOTTOM ARM IS INSTALLED TO THE STANDARD TEMPLATE, THIS IS ALSO EQUAL TO THE BOTTOM DOOR CLEARANCE.

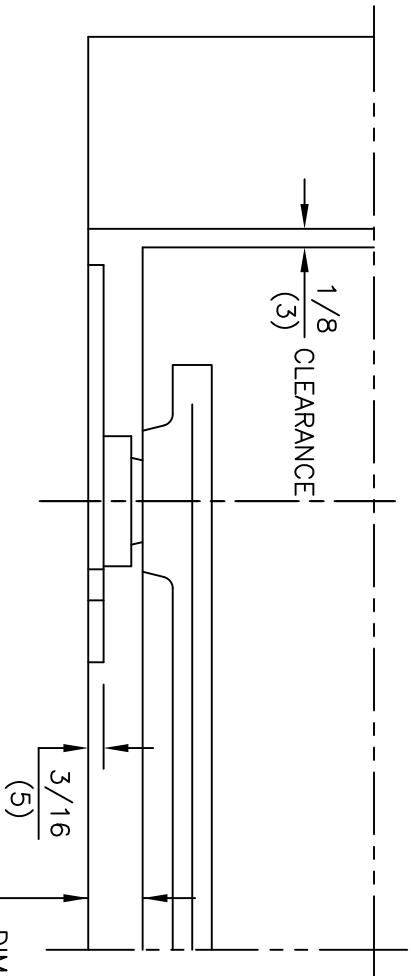

DIM. "A"  
 SEE NOTE #3

SPINDLE SIZE	DIM. "A"
STD.	1 1/16 (17)
5mm	7/8 (22)
10mm	1-1/16 (27)
15mm	1-1/4 (32)
20mm	1-7/16 (37)
25mm	1-5/8 (42)
30mm	1-7/8 (47)
35mm	2-1/16 (52)
40mm	2-1/4 (57)
45mm	2-7/16 (62)

ITEM No. 7471K  
 CENTER HUNG FLOOR BEARING INSTALLATION  
 FOR USE WITH 7421, 7422 BOTTOM ARMS

